



# Instruction Manual

Toftejorg TZ-89

IM-TE91A500-EN041

# Contents

Contents .....	1
Introduction .....	3
General Description .....	4
Functioning .....	4
Standard Configurations .....	5
Technical Data .....	6
Performance Data .....	7
Installation and Normal Operation .....	8
General Installation Instructions .....	8
Normal Operation .....	9
Preventive Maintenance .....	10
Recommended Preventive Maintenance .....	10
Dismantling and Assembling .....	12
Main Assembly .....	12
Gear Unit .....	14
Cleaner Head .....	16
How to Order Spare Parts .....	19
Claim Procedure .....	19
How to contact Alfa Laval Tank Equipment A/S .....	19
Exploded View Drawing .....	20
Reference List of Parts, Toftejorg TZ-89 .....	21
Reference List of Parts, Toftejorg TZ-89L .....	22
Spare Part Kits, Service Kits and Tools .....	23
Spare Part Kit for Toftejorg TZ-89, Article No. TE20A299 .....	23
Spare Part Kit for Toftejorg TZ-89LF, Article No. TE20A297 .....	23
Service Kit for Toftejorg TZ-89, Article No. TE20A285 .....	23
Service Kit for Toftejorg TZ-89LF, Article No. TE20A286 .....	23
Tools .....	23
Service Card .....	24
Claim Report Working Conditions .....	25



## Introduction

This manual has been prepared as a guide for the persons who will be operating and maintaining your tank cleaning machine.

The key to long life for your tank cleaning machine is a carefully planned system for preventive maintenance; you must appreciate that a tank cleaning machine which has a rough and dirty job to do will need more frequent attention than one working under ideal conditions.

**Note:** Get the best and most economical performance from your tank cleaning machine. Insufficient preventive maintenance means poor performance, unscheduled stops, shorter lifetime and extra costs. Good preventive maintenance on the contrary means good performance, no unscheduled stops and superior total economy.

The information in this manual is simple to follow, but should you require further assistance, our Customer Service Department and world-wide net of Distributors will be pleased to help you. Please quote the type, article and serial number with all your enquiries; this will help us to help you. The type, article and serial number are placed on the gear house of the tank cleaning machine.

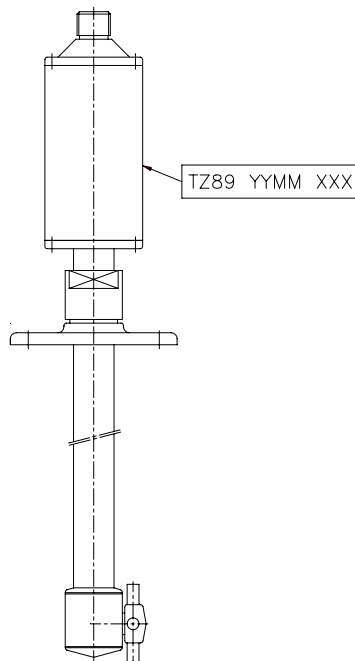

**Note:** The illustrations and specifications contained in this manual were effective at the date of printing. However, as continuous improvements are our policy, we reserve the right to alter or modify any unit specification on any product without prior notice or any obligation.

## General Description

The Toftejorg TZ-89 is a media driven and media lubricated tank cleaning machine. No lubricating substances such as oil or grease are used. All materials are selected for contact with food.

## Functioning

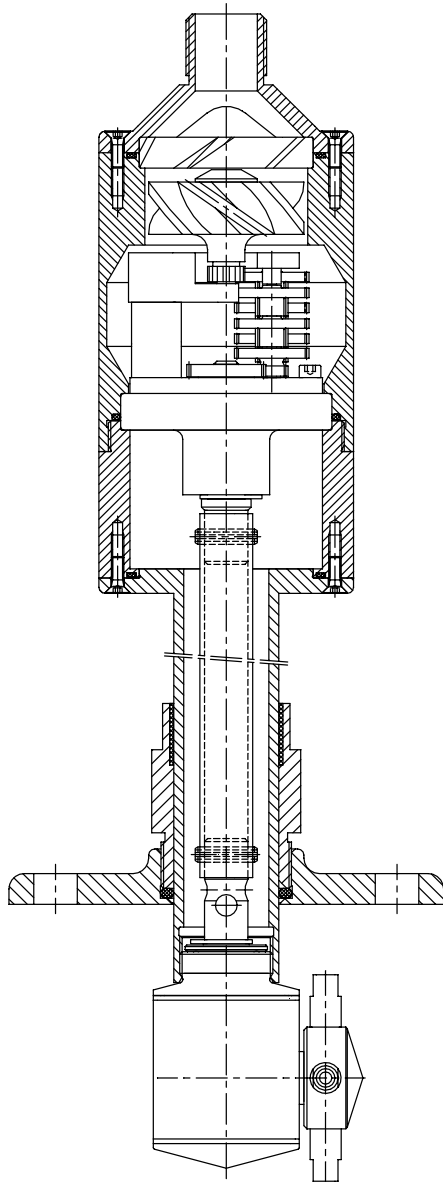

The flow of the cleaning fluid passes through a guide and a turbine, which accordingly is set into rotation. Through a gear set and a driver tube, the turbine rotation is transmitted to the Cleaner Head.

The 90° Angle gear in the Cleaner Head transmits the rotation from the gear unit to a horizontal rotation of the Cleaner Head body and a vertical rotation of the Nozzle head.

The combined motion of the Cleaner head and the Nozzle head ensures a fully indexed tank cleaning coverage. After  $5 \frac{1}{8}$  (for 2 nozzle version:  $10 \frac{1}{4}$ ) revolutions of the Nozzle head, corresponding to  $4 \frac{7}{8}$  (for 2 nozzle version:  $9 \frac{3}{4}$ ) revolutions of the cleaner head, a coarse cleaning pattern is laid out on the tank surface and the first cycle has been made. During the following cycles, this pattern is repeated 7 (for 2 nozzle version: 3) times, each of which is displaced and the pattern gradually becomes more dense. After 8 (for 2 nozzle version: 4) cycles - a total of 41 revolutions of the Nozzle head (39 revolutions of the Cleaner head), a complete cleaning pattern has been laid out, and the first pattern is repeated.

A complete cleaning pattern is illustrated below for a square tank with the machine placed in the centre:

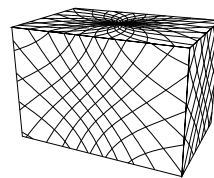

1. Cycle

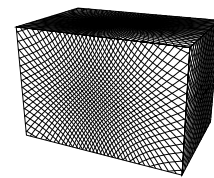

Complete pattern

## General Description (continued)

### Standard Configurations

Machine	Article No.	Inlet connection	Tank Connections	Length
TJ TZ-89	TE20A000	3/4" BSP	50ND6 DIN 2501	1020 mm
TJ TZ-89	TE20A003	1" Clamp	3" Clamp	1020 mm
TJ TZ-89L	TE20A004	3/4" BSP	50ND6 DIN 2501	1020 mm
TJ TZ-89L	TE20A006	1" Clamp	3" Clamp	1020 mm

TJ TZ-89L = Standard version 4x4 mm nozzles

TJ TZ-89L = "Low flow" 2x2.5 mm nozzles

Toftejorg TZ-89L is designed for small tanks, cleaning with low flow, fast rotation and has only 2 nozzles.

### Options

Machine	Article No.	Inlet Connection	Tank Connection	Length
TJ TZ-89	TE20A030	3/4"BSP	50ND6 DIN	350 mm
TJ TZ-89	TE20A031	3/4"BSP	50ND6 DIN	500 mm
TJ TZ-89	TE20A032	3/4"BSP	50ND6 DIN	750 mm
TJ TZ-89	TE20A033	3/4"BSP	50ND6 DIN	1270 mm
TJ TZ-89	TE20A034	3/4"BSP	50ND6 DIN	1500 mm
TJ TZ-89	TE20A002	3/4"NPT	3" ANSI	1020 mm
TJ TZ-89	TE20A040	3/4"NPT	3" ANSI	350 mm
TJ TZ-89	TE20A041	3/4"NPT	3" ANSI	500 mm
TJ TZ-89	TE20A042	3/4"NPT	3" ANSI	750 mm
TJ TZ-89	TE20A043	3/4"NPT	3" ANSI	1270 mm
TJ TZ-89	TE20A044	3/4"NPT	3" ANSI	1500 mm
TJ TZ-89	TE20A050	1" Clamp	3" clamp	350 mm
TJ TZ-89	TE20A051	1" Clamp	3" clamp	500 mm
TJ TZ-89	TE20A052	1" Clamp	3" clamp	750 mm
TJ TZ-89	TE20A053	1" Clamp	3" clamp	1270 mm
TJ TZ-89	TE20A054	1" Clamp	3" clamp	1500 mm
TJ TZ-89L	TE20A060	3/4"BSP	50ND6 DIN	350 mm
TJ TZ-89L	TE20A061	3/4"BSP	50ND6 DIN	500 mm
TJ TZ-89L	TE20A062	3/4"BSP	50ND6 DIN	750 mm
TJ TZ-89L	TE20A063	3/4"BSP	50ND6 DIN	1270 mm
TJ TZ-89L	TE20A064	3/4"BSP	50ND6 DIN	1500 mm
TJ TZ-89L	TE20A005	3/4"NPT	3" ANSI	1020 mm
TJ TZ-89L	TE20A070	3/4"NPT	3" ANSI	350 mm
TJ TZ-89L	TE20A071	3/4"NPT	3" ANSI	500 mm
TJ TZ-89L	TE20A072	3/4"NPT	3" ANSI	750 mm
TJ TZ-89L	TE20A073	3/4"NPT	3" ANSI	1270 mm
TJ TZ-89L	TE20A074	3/4"NPT	3" ANSI	1500 mm
TJ TZ-89L	TE20A080	1" Clamp	3" clamp	350 mm
TJ TZ-89L	TE20A081	1" Clamp	3" clamp	500 mm
TJ TZ-89L	TE20A082	1" Clamp	3" clamp	750 mm
TJ TZ-89L	TE20A083	1" Clamp	3" clamp	1270 mm
TJ TZ-89L	TE20A084	1" Clamp	3" clamp	1500 mm

Special version with PEEK Guide and Turbine Wheel: TE20AXXX-15.



## Technical Data (continued)

### Performance Data

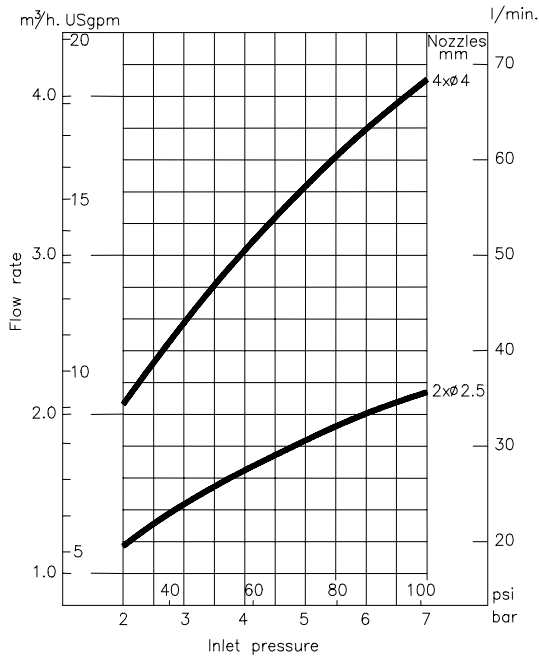

Capacity

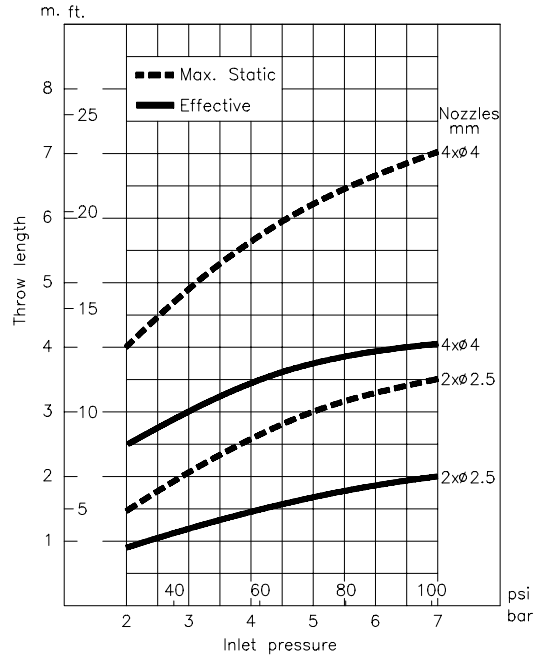

Throw length

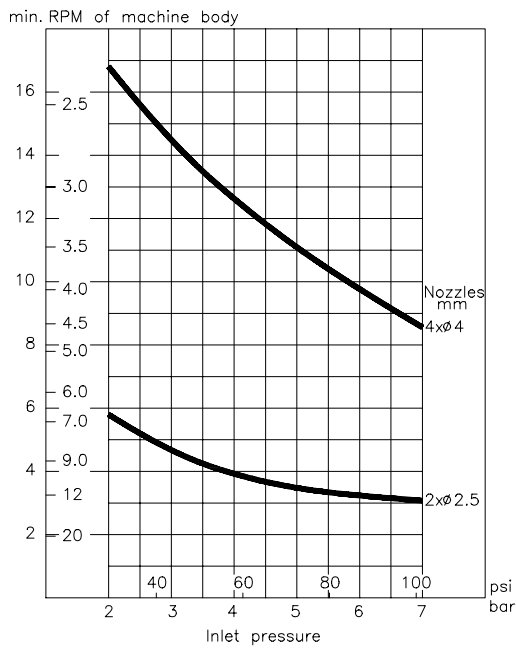

Cleaning Time, Complete Pattern

**Note:** Throw lengths are measured as horizontal throw length at static condition. Vertical throw length upwards is approx. 1/3 less.

Effective throw length is defined as impact centre of jet 250 mm water column (50 lbs/sq.ft). Effective throw length varies depending on jet transverse speed over surface, substance to be removed, cleaning procedure and agent.

The inlet pressure has been taken immediately before the machine inlet. In order to achieve the performance indicated in the curves, the pressure drop in the supply lines between pump and machine must be taken into consideration.

# Installation and Normal Operation

## General Installation Instructions

The Toftejorg TZ-89 is designed to be installed in a vertical upright position, however, the machine can operate horizontally or in any desired angle position.

The machine is equipped with a sliding and locking type flange connection, permitting to adjust the protruding of the cleaning head into the tank from 65 - 766 mm for the standard configuration. For the optional lengths, the max. protruding varies with the length.

It is recommended to install a filter with mesh size 250  $\mu\text{m}$  (0,01") in the supply line in order to avoid particles, scale, etc. from clogging inside the machine. It is essential to avoid fine solid particles, such as fine sand, in the cleaning fluid as they will increase wear considerably. This is particular important in case of recirculation.

It is recommended that the fluid valve fitted is of a type that prevents hydraulic shocks, which may cause severe damage to the entire installation.

Before installation, all supply lines and valves must be flushed to remove remains of welding electrodes, grinding dust, scale and other foreign matter.

**Note:** Do not try to turn Nozzle head by hand, since this will damage the Gear. Nozzle head can be turned by blowing air from an air pistol through the inlet connection.

**Note:** The machine shall be installed in accordance with national regulations for safety and other relevant regulations and standards. Precautions shall be made to prevent starting of the cleaning operation, while personnel are inside the tank or otherwise can be hit by jets from the nozzles. In EU-countries the complete system must fulfil the EU-machine directive and shall be CE-marked.

**Warning:**



If the machine is used in potential explosive atmospheres, tapes or joint sealing compounds which are electrical insulators must not be used on threads or joints. In addition, connecting pipe work, must be electrically conductive and earthed to the tank structure.

This is essential to avoid the build-up of static electricity on the machine.

## Installation and Normal Operation (continued)

### Normal Operation

#### Pressure

In order to protect the machine, your pipe and valve installation, etc. against damage:

Avoid hydraulic shocks! Put on pressure gradually!

Recommended working pressure: 3 - 6 bar (44 - 87 psi). Too high pressure will increase consumption of wear parts.

#### Cleaning Media

Use only cleaning fluids, which are compatible with Stainless Steel AISI 316/316L, SAF2205, FEP/Silicone, PEEK, PVDF and PTFE. Please note that PEEK is not resistant to concentrated sulfuric acid. Normal detergents, moderate solutions of acids and alkalics are acceptable as well as a number of solvents at ambient temperature during cleaning. The standard version of Toftejorg TZ-89 w. PVDF Guide and Turbine wheel is not compatible with solvents such as MEK, DMF, Acetone and Ethyl acetate. Use instead the special version with PEEK Guide and Turbine wheel. Aggressive chemicals, excessive concentrations of chemicals at elevated temperatures as well as certain dissolvents and hydrochlorides should be avoided. If you are in doubt, contact your local Alfa Laval Tank Equipment sales office.

#### After-Use Cleaning

Cleaning solutions must never be allowed to dry out in the machine, due to possible "salting out" or "scaling" of the cleaning ingredient. Therefore, the machine should always be flushed with fresh water after it has been used. The machine is self-draining.

## Preventive Maintenance

In order to keep your tank cleaning machine servicing you as an efficient tool in your tank cleaning operations, it is essential to maintain its high performance by following a simple preventive maintenance programme.

Good maintenance is careful and regular attention!

The following recommended preventive maintenance is based on tank cleaning machines working in average conditions. However, you will appreciate that a tank cleaning machine, which has a rough and dirty job to do, will need more frequent attention than one working in ideal conditions. We trust that you will adjust your maintenance programme to suit.

### Recommended Preventive Maintenance

Every 300 work hours disassemble the machine according to the instruction "Dismantling and Assembling" (page 12-17).

Clean material build-up and deposits from the internal parts. Inspect and clean the individual parts with Scotch-brite, S-Ultrafine, or chemical cleaner. Do not wipe with cotton waste, use always a non-fluffing cloth.

Special attention must be directed to the wear parts. To check which parts that are wear parts, please see Reference Lists of Parts, page 21-22. Replace worn or damaged parts.

When holding components in a vice, use lead or aluminium jaws or jaws made from other soft material. If it is necessary to knock any components, use a plastic hammer.

Never place parts directly on dirty floors or tables. Always place the parts on a piece of cloth, cardboard, etc.

Always perform all assembly/disassembly steps in the order described in this manual. Never assemble components without previous cleaning. Work in a well-lighted work area.

- Blank -

# Dismantling and Assembling

## Main Assembly

Important: The Cleaner head must never be unscrewed before the Gear unit has been taken out.

### Dismantling

1. Remove Screws (pos. 1). Lift off Inlet connection (pos. 2)
2. Lift off Guide (pos. 3) and remove O-ring (pos. 4)
3. Unscrew Gear house (pos. 5). Lift off the complete Gear unit (pos. 7) and remove O-ring (pos. 6)
4. Lift out the Driver tube (pos. 12). Unscrew Cleaner head (pos. 16) with a hook-spanner
5. After unscrewing the Pointed screw (pos. 13.2), unscrew Tank Connection (pos. 14) by turning Flange guide (pos. 13) and holding (pos.14)
6. Remove (pos. 14), Flange guide (pos. 13) and O-ring (pos. 15)
7. Remove screws (pos. 1), take off Gear house lower part (pos. 8) and O-ring (pos. 4)

For normal inspection and repair only steps 4.-7. are necessary.

### Reassembling

1. Place the O-ring (pos. 4) in the O-ring groove on Gear house lower part (pos. 8). Mount Gear house lower part on Centre tube (pos. 11)
2. Mount Screws (pos. 1) and tighten crosswise.
3. Slide on Flange guide (pos. 13), O-ring (pos. 15), and Tank connection (pos. 14) to Centre Tube (pos. 11). Connect Flange guide and Flange, and tighten. Tighten the Pointed screw (pos. 13.2).
4. Insert Driver tube (pos. 12) in Centre tube (pos. 11). Connect Driver tube and Cleaner head (pos. 16), screw on Cleaner head and tighten with hook-spanner.
5. Mount Gear unit (pos. 7). Make sure that Tubular rivet meshes into slot in Driver tube.
6. Place O-ring (pos. 6), mount Gear house (pos. 5) and tighten O-ring (pos. 4), Guide (pos. 3) and Inlet Connection (pos. 2).
7. Mount Screws (pos. 1) and tighten crosswise.

# Dismantling and Assembling (continued)

## Main Assembly (continued)

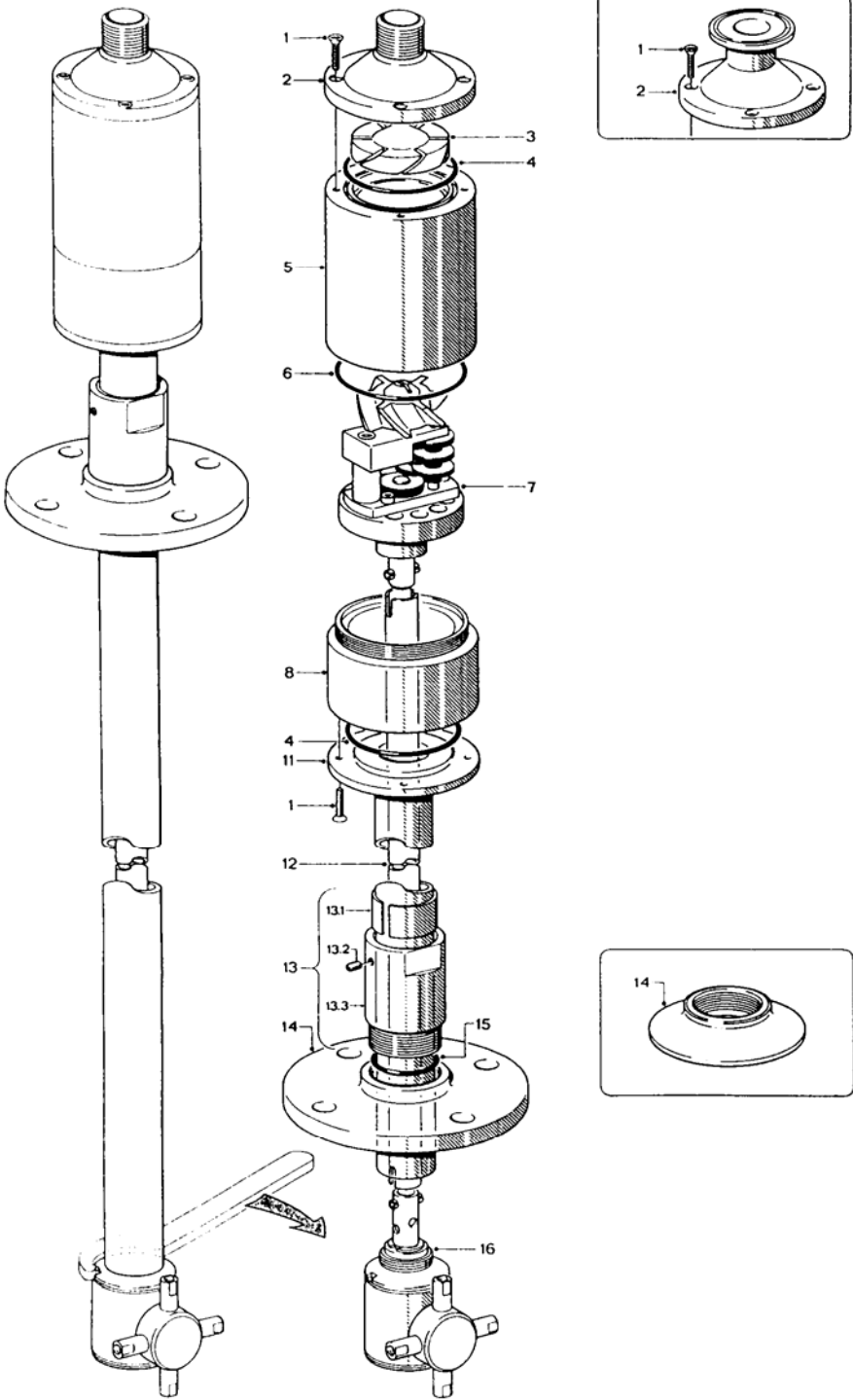

## Dismantling and Assembling (continued)

### Gear Unit

#### Dismantling

1. Screw off Turbine shaft (pos. 7.1) and take off Turbine wheel (pos. 7.2)
2. Unscrew Screw (pos. 7.3) and lift off Transverse (pos. 7.4)
3. Remove Distance bush (pos. 7.5), Gear wheel (pos. 7.6) and Gear wheel (pos. 7.7)
4. Unscrew the Screws (pos. 7.13) and lift off Gear frame (pos. 7.14)
5. Carefully knock out Tubular Rivet (pos. 7.12)
6. Take off the Circlip (pos. 7.16)
7. Push out Drive shaft (pos. 7.11) with Bearing bush (pos. 7.10) and Traction wheel (pos. 7.9)
8. Unscrew Traction wheel (pos. 7.9) **Note:** Left hand thread and remove Bearing bush (pos. 7.10)

#### Reassembling

1. Place Bearing bush (pos. 7.10) on Drive shaft (pos. 7.11) and screw on Traction wheel (pos. 7.9) (Left hand thread).
2. Mount the assembled Drive shaft in Bearing plate (pos. 7.15)
3. Mount the Circlip (pos. 7.16) on the Bearing bush (pos. 7.10)
4. Mount Tubular Rivet (pos. 7.12)
5. Mount Gear frame (pos. 7.14) and secure with Screws (pos. 7.13)
6. Mount Distance bush (pos. 7.5) on the one shaft and Stainless Steel Gear wheel (pos. 7.7) on the other (N/A in Toftejorg TZ-89L). Mount Gear wheels (pos. 7.6)
7. Mount Transverse (pos. 7.4) and secure with Screw (pos. 7.3), while holding Transverse.
8. Mount Turbine wheel (pos. 7.2) and Turbine shaft (pos. 7.1). Tighten Turbine shaft with a screwdriver.

# Dismantling and Assembling (continued)

## Gear Unit (continued)

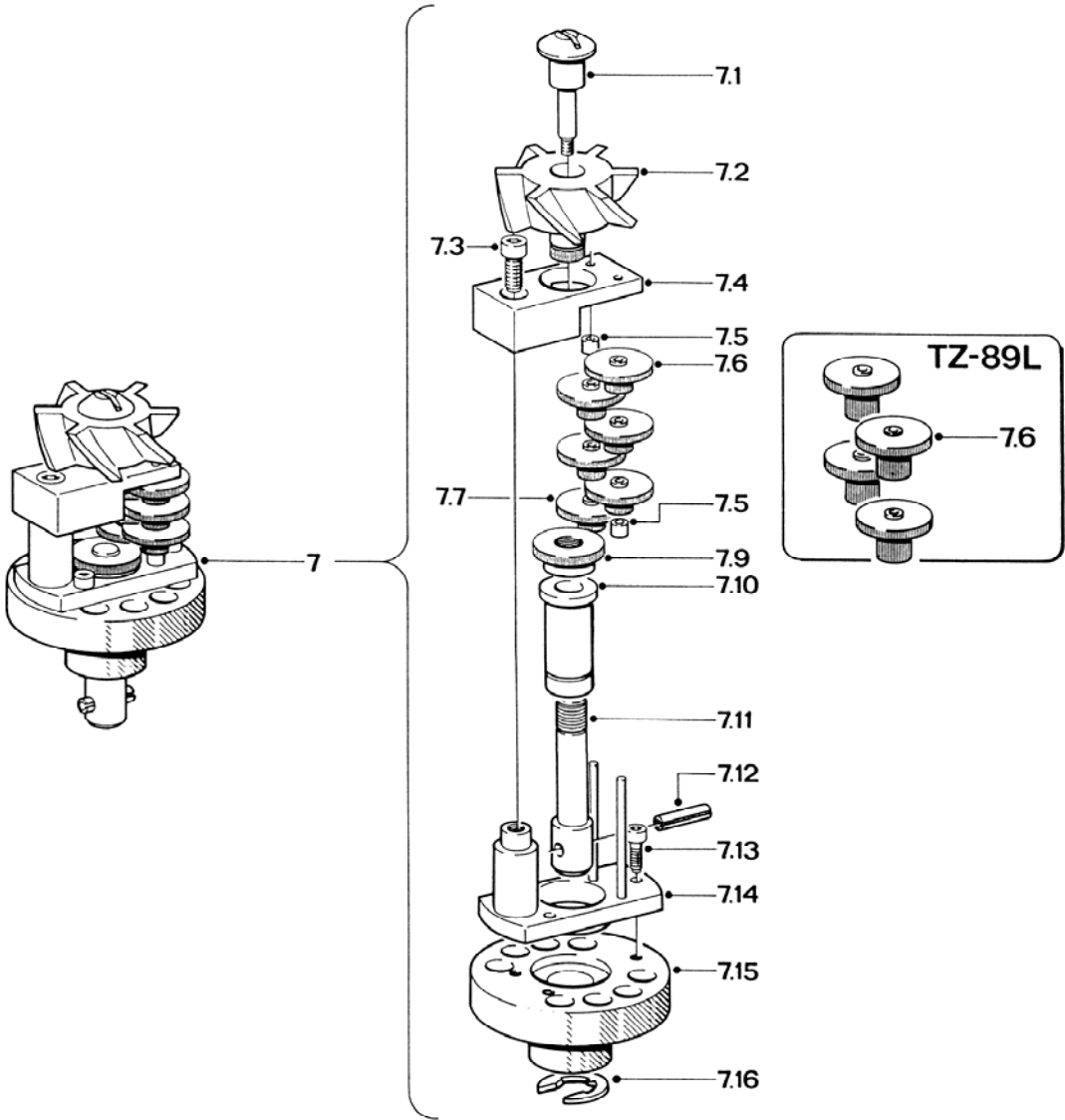

## Dismantling and Assembling (continued)

### Cleaner Head

#### Dismantling

1. Knock out Tubular Rivet (pos. 16.12)
2. Unscrew the Nozzle head (pos. 16.11) with Nozzles (pos. 16.10). Insert a screwdriver inside the shaft for Cleaner Head (pos. 16.18) into hole in Rotor (pos. 16.17), turn the Nozzle Head (pos. 16.11) anti-clockwise.
3. Remove Circlip (pos. 16.1)
4. Remove Bearing washer (pos. 16.2). Take out the Balls (pos. 16.3)
5. Lift off Stator (pos. 16.6) including the Bearing washer (pos. 16.4) and the Bush for stator (pos. 16.5)
6. Withdraw the Bearing washer (pos. 16.4) and the Bush for stator (pos. 16.5)
7. Lift off Sleeve (pos. 16.8). Remove the two Bushes (pos. 16.7)
8. Unscrew Screw (pos. 16.13), remove Spring washer (pos. 16.14) and Washer (pos. 16.15). Insert a screwdriver inside the shaft for Cleaner head (pos. 16.18) into hole in Rotor (pos. 16.17) to avoid rotation of Rotor.
9. Remove Rotor (pos. 16.17). If worn, replace the two Bushes (pos. 16.16)

Important: The two Bushes are press fitted and held by barbs. They will be damaged by withdrawing. Only withdraw Bushes if they are to be replaced.

#### Reassembling

1. Mount the new Bushes (pos. 16.16) in shaft for Cleaner head (pos. 16.18)
2. Mount Rotor (pos. 16.17), Washer (pos. 16.15), Spring washer (pos. 16.14) and Screw (pos. 16.13) and tighten. To secure Rotor against rotation insert a screwdriver through shaft for Cleaner head into a hole in the rotor.
3. Mount the two Bushes (pos. 16.7)
4. Locate Sleeve on shaft for Cleaner head (pos. 16.18)
5. Mount the Bush for stator (pos. 16.5) and Bearing washer (pos. 16.4) in the Stator (pos. 16.6)
6. Mount Stator (pos. 16.6)
7. Place the Balls (pos. 16.3) in the Stator (pos. 16.6)
8. Mount Bearing washer (pos. 16.4) and Circlip (pos. 16.1)
9. Screw on Nozzle head (pos. 16.11) and tighten. To secure Rotor against rotation, insert a screwdriver through shaft for Cleaner head into a hole in the Rotor.
10. Mount Tubular Rivet (pos. 16.12).

## Dismantling and Assembling (continued)

### Cleaner Head (continued)

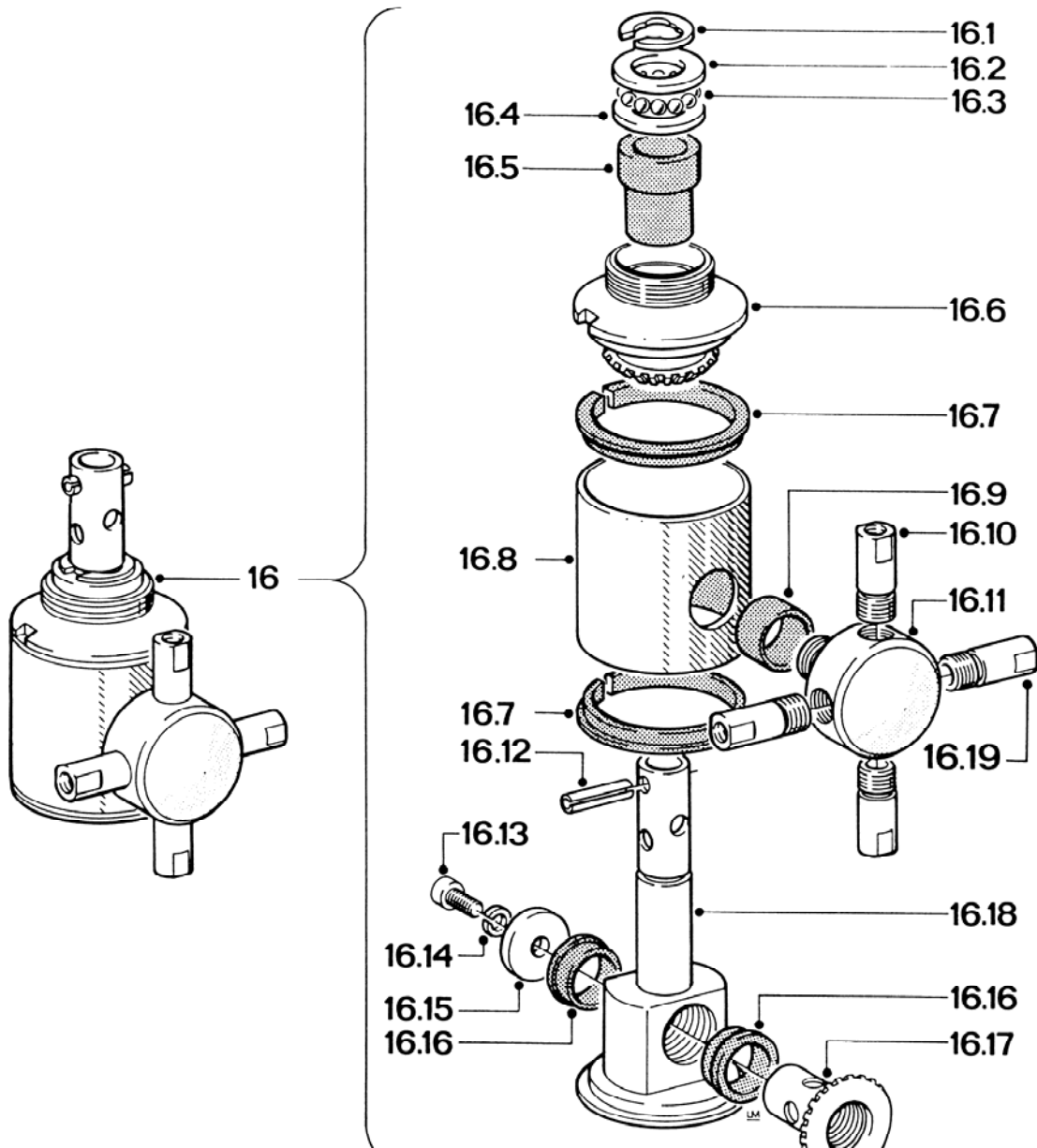

## Trouble Shooting Guide

### Symptom: Slow rotation or failure of machine to rotate

Possible Causes	Action
No or insufficient liquid flow	<p>a). Check if supply valve is fully open</p> <p>b). Check if inlet pressure to machine is correct</p> <p>c). Check nozzles for clogging</p> <p>d). Check supply line and filter for restriction/clogging.</p> <p>e). Dismount Connection nipple and Guide (see page 12) and check for clogging in Guide/Turbine wheel area.</p> <p>If large particles repeatedly get jammed in the machine, install filter or reduce mesh size of installed filter in supply line.</p>
Foreign material or material build-up	<p>Execute a total dismantling of the machine (pages 12-17). Remove foreign material/ material build up. Special attention must be paid to the Cleaner head assembly and the Gear unit assembly.</p> <p>Cleaner head and Turbine wheel must rotate freely without any sign of restriction.</p>
Mechanical defects	<p>Execute a total dismantling of the machine. Special attention must be paid to the wear parts - to find out which parts are wear parts, see Reference List of Parts, pages 21-22.</p> <p>Damaged parts must be replaced.</p>

## How to Order Spare Parts

On the Exploded View Drawing as well as on all instruction drawings, the individual parts have a position no., which is the same on all drawings. From the pos. no. the part is easily identified in the Reference Lists of Parts, pages 21-22.

Individual parts should always be ordered from the Reference Lists of Parts, pages 21-22. Ref. no. and Description should be clearly stated.

Please also quote the type of machine and serial no. This will help us to help you. The serial no. is stamped on the Connection Nipple on the top of the tank cleaning machine.

## Claim Procedure

In case of failure that needs assistance from Alfa Laval Tank Equipment A/S, it is essential for our evaluation that the problem as well as the working conditions of the machine are described as detailed as possible.

For description of the working conditions, fill in copy of Claim Report - Working Conditions, which you will find at the back of this manual.

## How to contact Alfa Laval Tank Equipment A/S

For further information please feel free to contact:

Alfa Laval Tank Equipment A/S  
Baldershoej 19  
P.O. Box 1149  
2635 Ishoej  
Denmark

Phone no.: +45 43 55 86 00  
Fax no.: +45 43 55 86 01  
[www.alfalaval.com](http://www.alfalaval.com)  
[www.toftejorg.com](http://www.toftejorg.com)

Contact details for all countries are continually updated on our websites.

# Exploded View Drawing

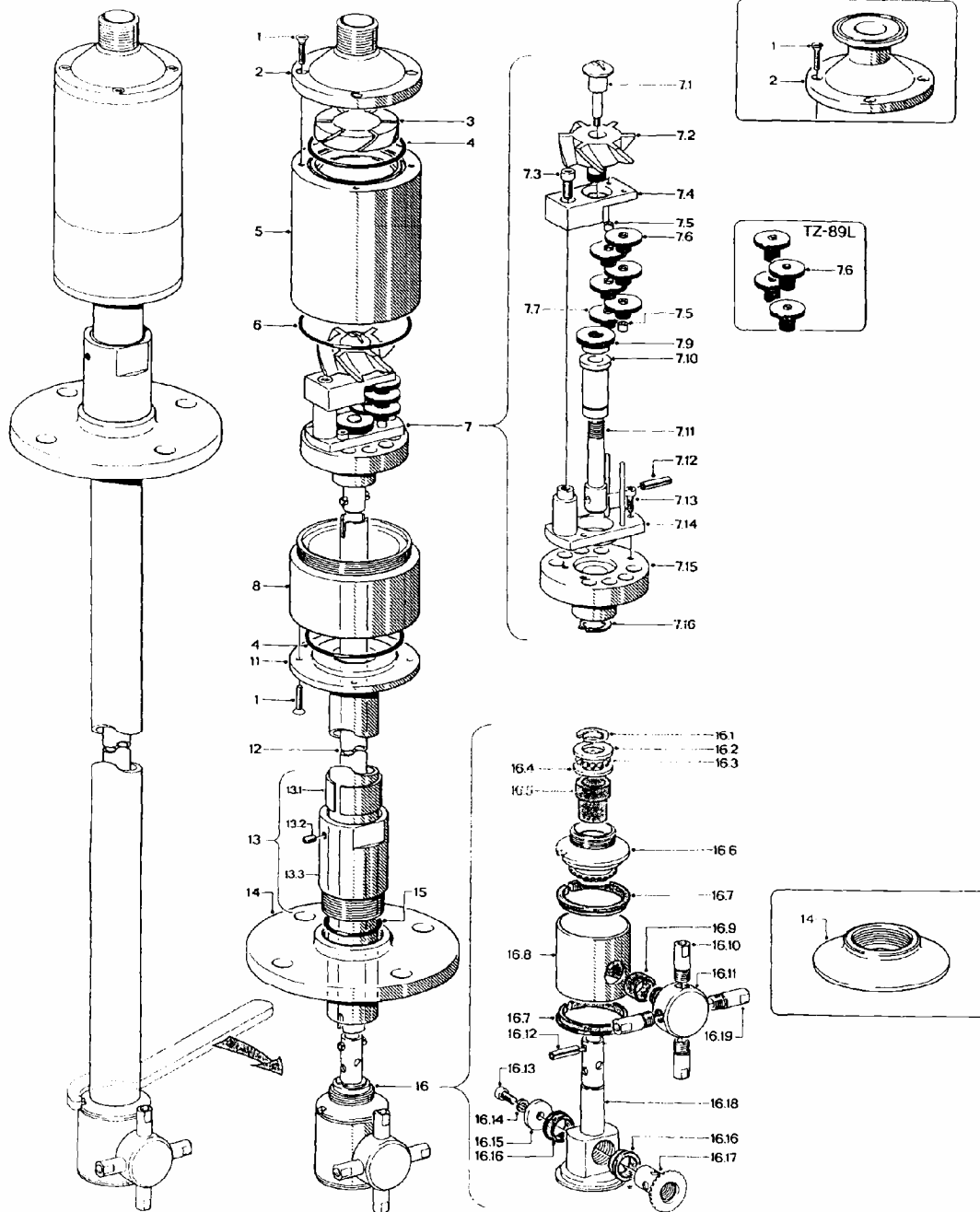

## Reference List of Parts, Toftejorg TZ-89

Pos.	Ref. No.	No/Unit	Description	Remarks
1	TE51A050	4	Screw	Spare part
2	<input type="checkbox"/> TE20A505	1	Connection nipple 3/4" BSP	Spare part
	<input type="checkbox"/> TE20A506	1	Connection nipple 3/4" NPT	Spare part
	<input type="checkbox"/> TE20A500	1	1" Clamp connection	Spare part
3	<input type="checkbox"/> TE20A520	1	Guide	Spare part
	<input type="checkbox"/> TE20A520-01	1	Guide, polymer	Spare part
4	TE51T034	2	O-ring	Spare part
5	TE20A510	1	Gear house	Spare part
6	TE51T036	1	O-ring	Spare part
7	TE20A307	1	Gear unit complete	Spare part
7.1	TE20A530	1	Turbine shaft	Wear part
7.2	<input type="checkbox"/> TE20A525	1	Turbine wheel	Wear part
	<input type="checkbox"/> TE20A525-01	1	Turbine wheel, polymer	Wear part
7.3	TE51A102	1	Screw	Spare part
7.4	TE20A535	1	Traverse	Spare part
7.5	TE20A555	2	Distance bush	Spare part
7.6	TE20A562	5	Gear wheel, polymer	Wear part
7.7	TE20A310	1	Gear wheel	Wear part
7.9	TE20A566	1	Traction wheel	Wear part
7.10	TE20A577	1	Bearing bush	Wear part
7.11	TE20A571	1	Drive shaft	Wear part
7.12	TE51C050	1	Tubular rivet	Wear part
7.13	TE51A101	3	Screw	Spare part
7.14	TE20A305	1	Gear frame	Wear part
7.15	TE20A580	1	Bearing plate	Spare part
7.16	TE51C200		See pos. 16.1	Wear part
8	TE20A515	1	Gear house lower part	Spare part
11	TE20A587/592	1	Centre tube	Spare part
12	TE20A581/586	1	Driver tube	Spare part
13	TE20A320	1	Flange guide	Spare part
13.1	TE20A602	1	Split bushing	Spare part
13.2	TE51A011	1	Pointed screw	Spare part
14	<input type="checkbox"/> TE20A605	1	Flange 50	Spare part
	<input type="checkbox"/> TE20A607	1	Flange 3"	Spare part
	<input type="checkbox"/> TE20A608	1	3" Clamp flange	Spare part
15	TE51T022	1	O-ring	Spare part
16	TE20A300	1	Cleaner head complete	Spare part
16.1	TE51C200	2	Circlip	Wear part
16.2	TE20A616	1	Bearing washer, upper	Wear part
16.3	TE126-2	12	Ball	Wear part
16.4	TE20A617	1	Bearing washer, lower	Wear part
16.5	TE20A623	1	Bush for stator	Wear part
16.6	TE20A626	1	Stator	Spare part
16.7	TE20A630	2	Bush	Wear part
16.8	TE20A635	1	Sleeve	Spare part
16.9	TE20A622	1	Bush	Wear part
16.10	TE20A655	4	Nozzle	Spare part
16.11	TE20A650	1	Nozzle head	Spare part
16.12	TE51C050	1	Tubular rivet	Wear part
16.13	TE51A100	1	Screw	Wear part
16.14	TE156	1	Spring washer	Wear part
16.15	TE20A640	1	Washer	Wear part
16.16	TE20A621	2	Collar bush	Wear part
16.17	TE20A645	1	Rotor	Wear part
16.18	TE20A610	1	Shaft for Cleaner head	Wear part

Configuration as delivered marked

Please note that some of the polymer parts are in PEEK, which is not resistant to concentrated sulfuric acid.

## Reference List of Parts, Toftejorg TZ-89L

Pos.	Ref. No.	No/Unit	Description	Remarks
1	TE51A050	4	Screw	Spare part
2	<input type="checkbox"/> TE20A505	1	Connection nipple 3/4" BSP	Spare part
	<input type="checkbox"/> TE20A506	1	Connection nipple 3/4" NPT	Spare part
	<input type="checkbox"/> TE20A500	1	1" Clamp connection	Spare part
3	<input type="checkbox"/> TE20A520	1	Guide	Spare part
	<input type="checkbox"/> TE20A520-01	1	Guide, polymer	Spare part
4	TE51T034	2	O-ring	Spare part
5	TE20A510	1	Gear house	Spare part
6	TE51T036	1	O-ring	Spare part
7	TE20A308	1	Gear unit complete	Spare part
7.1	TE20A530	1	Turbine shaft	Wear part
7.2	<input type="checkbox"/> TE20A525	1	Turbine wheel	Wear part
	<input type="checkbox"/> TE20A525-01	1	Turbine wheel, polymer	Wear part
7.3	TE51A102	1	Screw	Spare part
7.4	TE20A535	1	Traverse	Spare part
7.5	TE20A555	2	Distance bush	Spare part
7.6	TE20A559	4	Gear wheel, polymer	Wear part
7.9	TE20A566	1	Traction wheel	Wear part
7.10	TE20A577	1	Bearing bush	Wear part
7.11	TE20A571	1	Drive shaft	Wear part
7.12	TE51C050	1	Tubular rivet	Wear part
7.13	TE51A101	3	Screw	Spare part
7.14	TE20A305	1	Gear frame	Wear part
7.15	TE20A580	1	Bearing plate	Spare part
7.16	TE51C200		See pos. 16.1	Wear part
8	TE20A515	1	Gear house lower part	Spare part
11	TE20A587/592	1	Centre tube	Spare part
12	TE20A581/586	1	Driver tube	Spare part
13	TE20A320	1	Flange guide	Spare part
13.1	TE20A602	1	Split bushing	Spare part
13.2	TE51A011	1	Pointed screw	Spare part
14	<input type="checkbox"/> TE20A605	1	Flange 50	Spare part
	<input type="checkbox"/> TE20A607	1	Flange 3"	Spare part
	<input type="checkbox"/> TE20A608	1	3" Clamp flange	Spare part
15	TE51T022	1	O-ring	Spare part
16	TE20A301	1	Cleaner head complete	Spare part
16.1	TE51C200	2	Circlip	Wear part
16.2	TE20A616	1	Bearing washer, upper	Wear part
16.3	TE126-2	12	Ball	Wear part
16.4	TE20A617	1	Bearing washer, lower	Wear part
16.5	TE20A623	1	Bush for stator	Wear part
16.6	TE20A626	1	Stator	Spare part
16.7	TE20A630	2	Bush	Wear part
16.8	TE20A635	1	Sleeve	Spare part
16.9	TE20A622	1	Bush	Wear part
16.10	TE20A652	2	Nozzle	Spare part
16.11	TE20A650	1	Nozzle head	Spare part
16.12	TE51C050	1	Tubular rivet	Wear part
16.13	TE51A100	1	Screw	Wear part
16.14	TE156	1	Spring washer	Wear part
16.15	TE20A640	1	Washer	Wear part
16.16	TE20A621	2	Collar bush	Wear part
16.17	TE20A645	1	Rotor	Wear part
16.18	TE20A610	1	Shaft for Cleaner head	Wear part
16.19	TE20A660	2	Plug	Spare part

Configuration as delivered marked

Please note that some of the polymer parts are in PEEK, which is not resistant to concentrated sulfuric acid.

## Spare Part Kits, Service Kits and Tools

### Spare Part Kit for Toftejorg TZ-89, Article No. TE20A299

Pos. no.	Reference no.	No.	Description
4	TE51T034	2	O-ring
6	TE51T036	1	O-ring
15	TE51T022	1	O-ring
7.6	TE20A562	5	Gear wheel, polymer
16.2	TE20A616	1	Bearing washer, upper
16.4	TE20A617	1	Bearing washer, lower

### Spare Part Kit for Toftejorg TZ-89LF, Article No. TE20A297

Pos. no.	Reference no.	No.	Description
4	TE51T034	2	O-ring
6	TE51T036	1	O-ring
15	TE51T022	1	O-ring
7.6	TE20A559	4	Gear wheel, polymer
16.2	TE20A616	1	Bearing washer, upper
16.4	TE20A617	1	Bearing washer, lower

### Service Kit for Toftejorg TZ-89, Article No. TE20A285

Pos. no.	Reference no.	No.	Description
16.3	TE126-2	12	Ball for Thrust bearing
7.6	TE20A562	5	Gear wheel
16.2	TE20A616	1	Bearing washer Upper
16.4	TE20A617	1	Bearing washer Lower
16.16	TE20A621	2	Collar bush
16.9	TE20A622	1	Bush
16.5	TE20A623	1	Bush for Stator
16.7	TE20A630	2	Bush
1	TE51A050	8	Screw
4	TE51T034	2	O-ring

### Service Kit for Toftejorg TZ-89LF, Article No. TE20A286

Pos. no.	Reference no.	No.	Description
16.3	TE126-2	12	Ball for Thrust bearing
7.6	TE20A559	4	Gear wheel
16.2	TE20A616	1	Bearing washer Upper
16.4	TE20A617	1	Bearing washer Lower
16.16	TE20A621	2	Collar bush
16.9	TE20A622	1	Bush
16.5	TE20A623	1	Bush for Stator
16.7	TE20A630	2	Bush
1	TE51A050	8	Screw
4	TE51T034	2	O-ring

## Tools

Reference no.	Description
TE81B039	Hook-spanner spanner Hex key for Allen Screw



# Claim Report Working Conditions

Page 1/2

**Ref. Claim Case** : \_\_\_\_\_

**Machine/Cleaner Type** : \_\_\_\_\_ **Serial No.:** \_\_\_\_\_

Configuration

- Nozzles : \_\_\_\_\_ x  $\varnothing$  \_\_\_\_\_ mm

- Turbine/Inlet Guide : \_\_\_\_\_ %

## Working Conditions

Inlet pressure at machine/cleaner : \_\_\_\_\_

Type of Valve in inlet line : \_\_\_\_\_

Can hydraulic shock be disregarded: :  Yes  No

Inlet line flushed before installation of tank cleaner? :  Yes  No

Working hours before failure : \_\_\_\_\_ hours

## Cleaning Programme

Cleaning media and conc.	Temperature	Time	Recirculation?

Is sterilising being used? :  Yes  No

Procedure (media/temp.)? : \_\_\_\_\_

Is steam injection being used for heating? :  Yes  No

Time: \_\_\_\_\_

Temperature: \_\_\_\_\_

## Claim Report Working Conditions (continued)

Page 2/2

### Condition of Cleaning Media

- |   |   |
|---|---|
| <input type="checkbox"/> Clean                                      |   |
| <input type="checkbox"/> Contaminated with (nature and description) |   |
| <input type="checkbox"/> Chemicals/Solvents _____                   | <input type="checkbox"/> High viscous     |
| <input type="checkbox"/> Soluble                                    | <input type="checkbox"/> Sticky/tenacious |
| <input type="checkbox"/> Low viscous                                | <input type="checkbox"/> Solidifying      |
| <input type="checkbox"/> Hard particles/size _____                  | <input type="checkbox"/> Crystallizing    |
| <input type="checkbox"/> Soft particles/size _____                  |   |

Has filter been installed in inlet line?

- |                              |    |
|------------------------------|----|
| <input type="checkbox"/> Yes |    |
| Mesh size: _____             | mm |
| <input type="checkbox"/> No  |    |

Is tank cleaner flushed with clean water after tank cleaning?

- |                              |                             |
|------------------------------|-----------------------------|
| <input type="checkbox"/> Yes | <input type="checkbox"/> No |
|------------------------------|-----------------------------|

### Type of Soilage/Tank Contents to be removed

Name, formula/concentration of material to be removed from tank : \_\_\_\_\_

What is material soluble in : \_\_\_\_\_

Nature of material:

- |   |   |  |
|---|---|--|
| <input type="checkbox"/> Volatile/explosive | <input type="checkbox"/> Sticky/tenacious | <input type="checkbox"/> Contains soft particles |
| <input type="checkbox"/> Low viscous        | <input type="checkbox"/> Solidifying      | <input type="checkbox"/> Contains hard particles |
| <input type="checkbox"/> High viscous       | <input type="checkbox"/> Crystallizing    |  |

Is tank cleaner submerged in material?

- |                              |                             |
|------------------------------|-----------------------------|
| <input type="checkbox"/> Yes | <input type="checkbox"/> No |
|------------------------------|-----------------------------|

### Other information/Remarks

---

---

Date: \_\_\_\_\_

Sign.: \_\_\_\_\_

S3.3, Vers 98.1