



# Instruction Manual

Toftejorg TZ-79

IM-TE91A350-EN1  
March 2005

# Contents

Contents .....	1
Introduction .....	3
General Description.....	4
Functioning .....	4
Standard configurations .....	5
Standard options .....	5
Technical data .....	6
Installation and Normal Operation.....	8
General Installation Instructions.....	8
Normal Operation.....	9
Maintenance and Repair .....	10
Preventive Maintenance.....	10
Top Assembly .....	12
Bottom Assembly .....	14
Hub Subassembly.....	16
Stem Subassembly .....	18
Gear Subassembly .....	20
Replacement of Collar Bushes.....	22
Replacement of Ball races .....	24
Replacement of Main Collars .....	26
Tools .....	28
Standard Tool kit for Toftejorg TZ-79 .....	28
Sketch of tools for replacement of Main collars.....	29
Trouble Shooting Guide .....	30
Reference List of Parts .....	32
Cross Sectional Drawing .....	33
Service Kits.....	34
Standard Service Kit for Toftejorg TZ-79 .....	34
Optional Service Kit for Toftejorg TZ-79 with Polymer Wear Parts .....	34
How to order spare parts and claim procedure .....	35
How to contact Alfa Laval Tank Equipment A/S.....	35
Service Card.....	36
Claim Report Working Conditions .....	37

## Introduction

This manual has been prepared as a guide for the persons who will be operating and maintaining your tank cleaning machine. The key to long life for your tank cleaning machine will always be a system of carefully planned maintenance; you will appreciate that a tank cleaning machine which has a rough and dirty job to do will need more frequent attention than one working in ideal conditions.

It is in your own interest to get the best and most economical performance from your tank cleaning machine. Neglect of maintenance means poor performance, unscheduled stoppages, shorter life and expense. Good maintenance means good performance; no unscheduled stoppages and better total economy.

You will find the information contained in this manual simple to follow, but should you require further assistance, our Customer Service Department and world-wide net of Distributors will be pleased to help you. Please quote the type and serial number with all your enquiries; this will help us to help you. The type and serial number are placed on the gear house of the tank cleaning machine.

**Note:** The illustrations and specifications contained in this manual were effective at the date of printing. However, as continuous improvement is the policy of Alfa Laval Tank Equipment, we reserve the right to alter or modify any unit specification on any product without notice or any obligation.

## General Description

The Toftejorg TZ-79 is a media driven and media lubricated tank cleaning machine. As it is self lubricating, there is no lubricating substances such as oil, grease etc. in the machine which needs to be regularly changed.

## Functioning

The flow of the cleaning fluid into the machine passes through a guide and a turbine, which is set into rotation. The turbine rotation is through a gearbox transformed into a combined horizontal rotation of the machine body and a vertical rotation of the nozzles.

The combined motion of the machine body and the nozzles ensures a fully indexed tank cleaning coverage. After  $5\frac{5}{8}$  revolutions of Hub with nozzles ( $5\frac{5}{8}$  revolutions of the machine body), one coarse cleaning pattern is laid out on the tank surface. During the following rounds, this pattern is repeated 7 times, each of which is displaced  $\frac{1}{8}$  of the mesh in the pattern. After a total of 45 revolutions of the Hub with nozzles (43 revolutions of the machine body), a complete cleaning pattern has been laid out, and the first pattern is repeated.

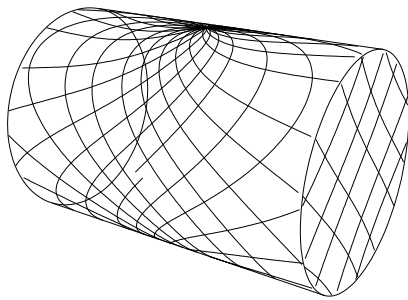

First cycle

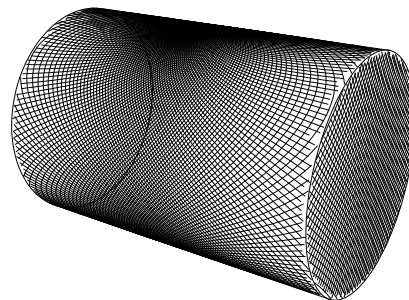

Full pattern

The speed of rotation of the turbine depends on the flow rate through the machine. The higher the flow rate is, the higher the speed of rotation will be. In order to control the RPM of the machine for a wide range of flow rates, the efficiency of the turbine can be changed (100% and 0% Turbine/Inlet guide).

Apart from the jet flow through the nozzles, fluid is leaking through the top of the machine, at the hub and through the bottom cover. The leakages between the moving parts at the top and at the hub are cleaning the gabs and thus preventing build-up of material that might cause extra friction. The flow through the bottom cover is due to the fact that the machine is media lubricated, and that accordingly a flow through the gearbox is needed.

## General description (continued)

### Standard configurations

Connection	Turbine/ Inlet Guide	Nozzles (mm) (3/4" thread connection)	Article No.
<u>Top cone:</u>			
2" BSP, Female	100%	4xø8	TE22D210
		4xø9	TE22D212
		2xø11	TE22D216
	0 %	4xø9	TE22D230
		4xø10	TE22D232
<hr/>			
<u>Top cone:</u>			
2" NPT, Female	100%	4xø8	TE22D110
		4xø9	TE22D112
		2xø11	TE22D116
	0%	4xø9	TE22D130
		4xø10	TE22D132

The machine is equipped with a clutch in the hub, which gives the possibility of rotating by hand the nozzles, when the machine is to be lifted out through a tank opening.

### Standard options

Machines with polymer wear parts: TE22Dxxx-06.

## Technical data

Weight of machine	:	13 kgs (28,6 lb)
Working pressure	:	2-12 bar (30-175 psi)
Recommended inlet pressure	:	3-8 bar (45-120 psi)
Working temperature max.	:	95° (200° F)
Materials	:	Stainless steel AISI 316/316L, PTFE, Tefzel, PVDF, Carbon, Teflon TFM, PEEK

## Principal dimensions in mm

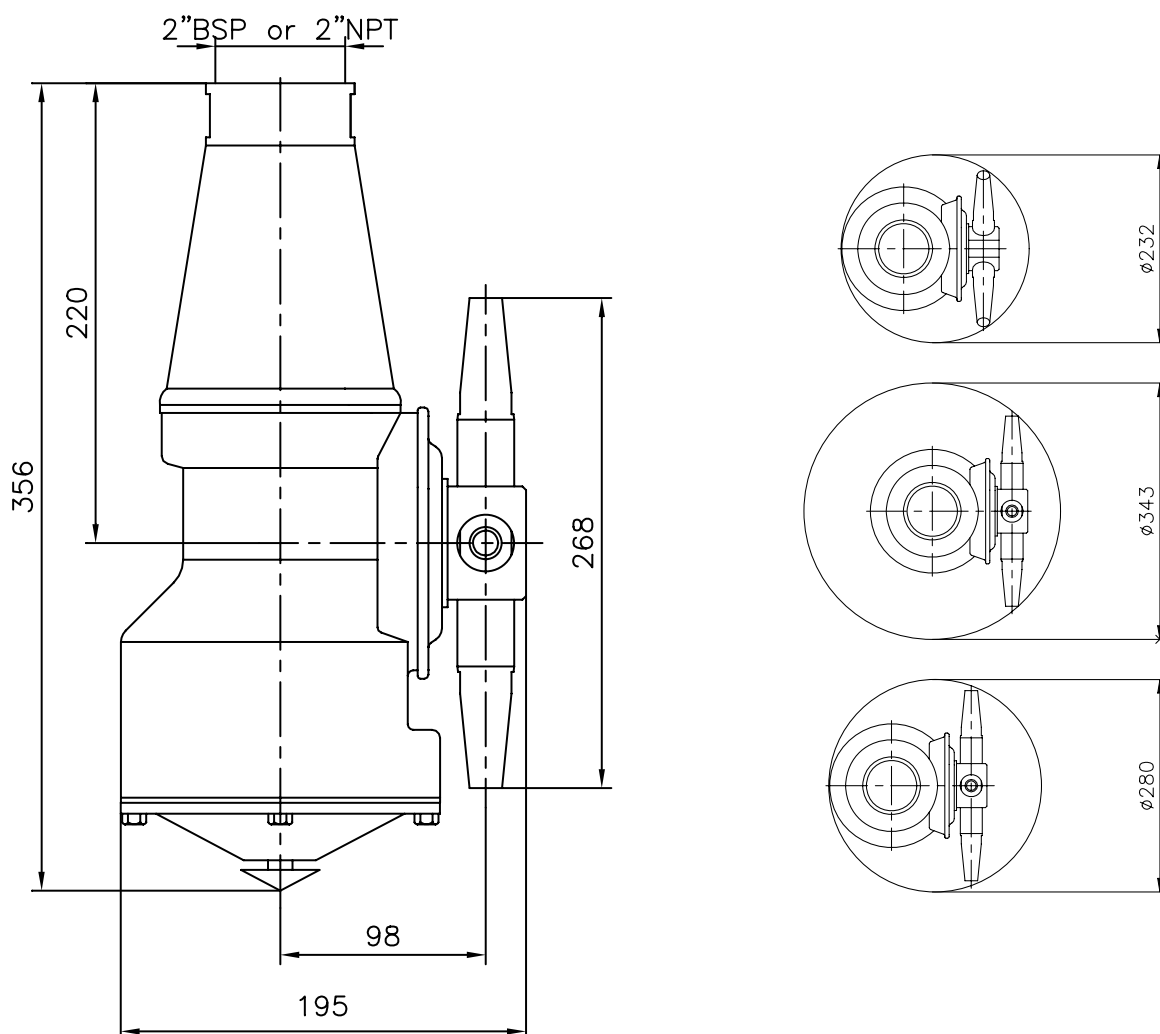

## Technical data (continued)

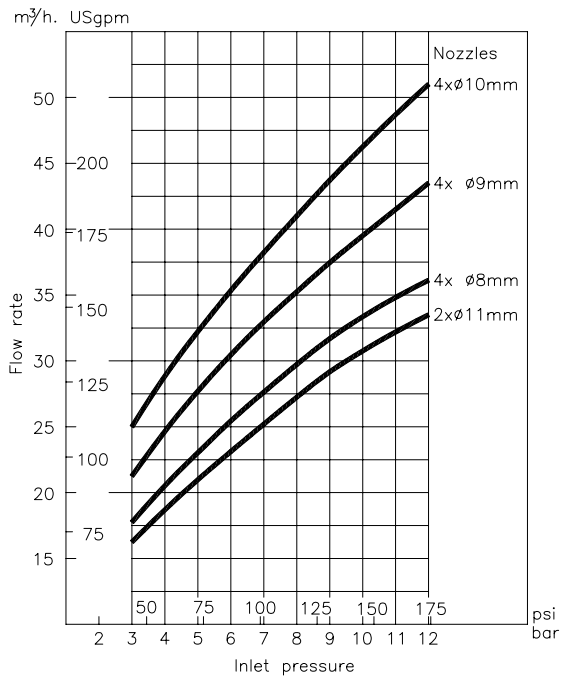

Flow rate

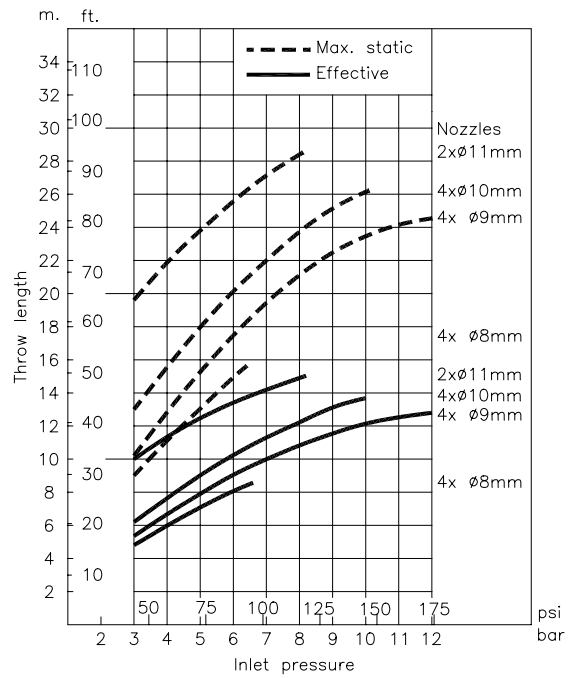

Throw length

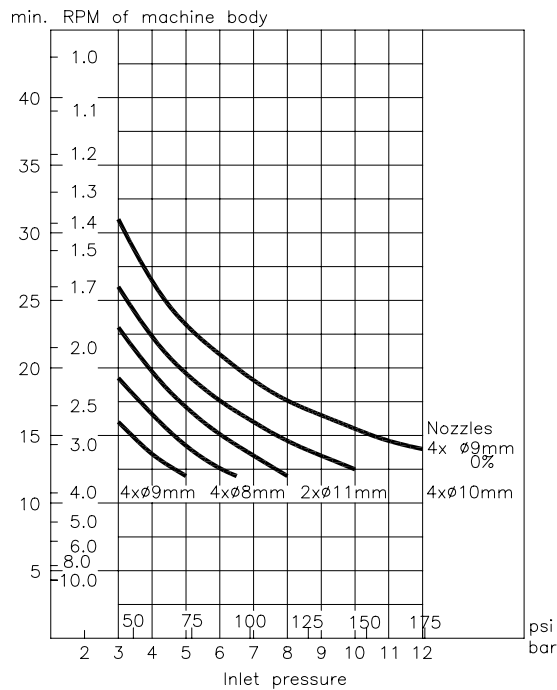

Cleaning Time f. complete Pattern (= 8 cycles)

**Note:** Throw lengths are measured as horizontal throw length at static condition. Vertical throw length upwards is approx. 1/3 less.

Effective throw length is defined as impact centre of jet 250 mm water column (50 lbs/sq.ft). Effective throw length varies depending on jet transverse speed over surface, substance to be removed, cleaning procedure and agent.

The inlet pressure has been taken immediately before the machine inlet. In order to achieve the performance indicated in the curves, the pressure drop in the supply lines between pump and machine must be taken into consideration

# Installation and Normal Operation

## General Installation Instructions

The tank cleaning machine should be installed in vertical position (upright or upside down). It is recommended to install a filter in the supply line in order to avoid large particles to clog inside the machine. Before connecting the machine into the system, all supply lines and valves should be flushed to remove foreign matter.

For devices with tapered thread connections to the down pipe, it is recommended that you secure the connection in a manner appropriate for the application. Subject to the intended use environment and any in-house user requirements or policies, a liquid threadlocking adhesive such as Loctite No. 243 or equivalent could be used. Other methods could be acceptable and subject to customer preference.

**Note:** The machine shall be installed in accordance with national regulations for safety and other relevant regulations and standards.  
Precautions shall be made to prevent starting of the cleaning operation, while personnel are inside the tank or otherwise can be hit by jets from the nozzles.  
In EU-countries the complete system must fulfil the EU-machine directive and shall be CE-marked.

**Warning:**



If the machine is used in potential explosive atmospheres, tapes or joint sealing compounds which are electrical insulators must not be used on threads or joints, unless an electrical connection is otherwise established to ensure an effective earthing. In addition, connecting pipe work, must be electrically conductive and earthed to the tank structure. The resistance between the nozzles and the tank structure should not exceed 20,000 Ohm. This is essential to avoid the build-up of static electricity on the machine.

For further information see CENELEC R044-001 Safety of Machinery, guidance and recommendations for the avoidance of hazards due to static electricity.

The machine as delivered has been tested at the factory before shipping. For transportation reasons, the nozzles have been screwed off after the test. In order to secure the nozzles against falling off due to vibrations and other external strains it is important that the nozzles are tightened properly after mounting. If not, the nozzles may be blown off during tank cleaning and cause severe damage on tank, valves and pump. This is especially important if machines are fixed installed in tanks and vessels within the transportation sector in trucks, railcars and onboard ships.

Normally, it is sufficient to tighten the nozzles with the specified torque. However, depending on the application and local policies an extra securing may be preferred.

Subject to the intended use, environment and any inhouse user requirements or policies, a liquid threadlocker such as Loctite No. 243 or equivalent could be used. Other methods could be acceptable and subject to customer preference. For detailed instruction on pre-cleaning and application of the product carefully follow the instruction on the used locking system.

## Installation and Normal Operation (continued)

1. Clamp machine firmly in a vice. Protect machine with rubber pad under the machine and use rubber jaws on the vice. Mount jaws upside down to ensure firm grip on the machine. Set torque wrench at the specified tightening torque.
2. Hold one nozzle with flat spanner to counteract while tightening the opposite nozzle with the torque wrench.

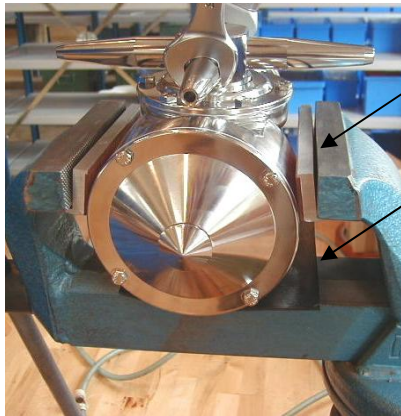

Rubber jaw mounted upside down

Protect with rubber pad



Recommended tightening torque: 50 Nm

3. Check that the machine is in operating condition by inserting hex Screwdriver (tool No. TE134A) in screw in top of Turbine shaft and easily turn Turbine shaft clockwise. If any resistance is recognised, the machine should be disassembled to localise the cause.

## Normal Operation

### Cleaning Media

Use only cleaning fluids compatible with Stainless Steel AISI 316/316L, PTFE, Tefzel, PVDF, Carbon, PEEK and Teflon, TFM. Please note that PEEK is not resistant to concentrated sulfuric acid. Normal detergents, moderate solutions of acids and alkalis will be acceptable. Aggressive chemicals, excessive concentrations of chemicals at elevated temperatures, as well as certain hypochlorites should be avoided. If you are in doubt, contact your local Alfa Laval Tank Equipment sales office.

### After Use Cleaning

After use flush the machine with fresh water. Cleaning solutions should never be allowed to dry or set-up in the system due to possible "salting out" or "scaling" of the cleaning ingredient. If cleaning media contains volatile chloride solvents, it is recommended not to flush with water after use, in case this can create hydrochloric acid.

### Pressure

Avoid Hydraulic shocks. Put on pressure gradually. Do not exceed 12 bar inlet pressure. Recommended inlet pressure appears from Technical Data (page 6-7). High pressure in combination with high flow rate will increase consumption of wear parts.

# Maintenance and Repair

## Preventive Maintenance

In order to keep your tank cleaning machine servicing you as an efficient tool in your tank cleaning operations, it is essential to maintain its high performance by following a simple preventive maintenance programme, which will always keep your tank cleaning machine in good condition.

Good maintenance is careful and regular attention!

The following recommended preventive maintenance is based on tank cleaning machines working in average conditions. However, you will appreciate that a tank cleaning machine, which has a rough and dirty job to do, will need more frequent attention than one working in ideal conditions. We trust that you will adjust your maintenance programme to suit.

Always use only proper tools. Use Toftejorg TZ-79 standard tool kit. Never force, hammer or pry components together or apart. Always perform all assembly/disassembly steps in the order described in this manual.

Never assemble components without previous cleaning. This is especially important at all mating surfaces. Work in a clear well lighted work area.

### Every 300 working hours

1. Disassemble machine as described on the following pages.
2. Clean material build-up and deposits from internal parts with chemical cleaner and/or if desired fine abrasive cloth.
3. Check Slide bearings (pos. 30) for wear. If hole is worn oval to max. diameter more than 12.4 mm, Slide bearing should be replaced. If end face of Slide bearing is worn more than x mm into Slide bearing, it should be replaced.

Under Turbine shaft:  $x = 1.5 \text{ mm}$

At Horizontal shaft:  $x = 0.5 \text{ mm}$

4. Check Collar bushes (pos. 12) in Gear frame. If holes are worn oval to max. diameter more than 15.4 mm, Collar bush should be replaced. How to replace Collar bushes, see page 22.

**Note:** Timely replacement of Slide bearings and Collar bushes will prevent costly damage to the gearbox.

## **Maintenance and Repair (continued)**

### **Preventive Maintenance**

5. Check Worm wheels (pos. 13 and pos. 14). If extremely worn, they should be replaced.
6. Check Main bush (pos. 6). If worn oval to max. diameter more than 15.4 mm, it should be replaced.
7. Assemble machines as described in the following pages.
8. Check that the machine is in operating condition by inserting hex Screwdriver (tool No. TE134A) in screw in top of Turbine shaft and easily turn Turbine shaft clockwise. If any resistance is recognized, the machine should be disassembled to localize the cause.

Apart from the parts specifically mentioned above, all the remaining wear parts should regularly be inspected for wear. Which parts that are wear parts appear from Reference List of Parts, page 32.

### **Service Card**

For your registration of maintenance carried out, fill in service card which you will find at the back of this manual (see page 36).

## Maintenance and Repair (continued)

### Top Assembly

#### Disassembly

1. Remove Screws (pos. 19). Loosen and unscrew with a Socket wrench (tool No. TE962A).
2. Lift off Top cone (pos. 1).
3. Remove Guide/Guide ring (pos. 2). The Guide has a groove in the outer diameter. The Guide is easily lifted out of the Stem by means of two ordinary Screwdrivers inserted into the groove.
4. Remove Screw (pos. 17), Spring washer (pos. 16) and Washer (pos. 18). To secure Impeller against rotation, insert carefully Screwdriver (tool no. TE135A), through Impeller (pos. 4) into a hole in the Stem.
5. Pull off Impeller (pos. 4).

#### Reassembly

1. Reinstall Impeller (pos. 4). Make sure that Impeller is correctly rotated to be pushed onto Turbine shaft. Do not try to hammer Impeller in position, as this will damage Slide bearing under Turbine shaft.
2. Mount Washer (pos. 18), Spring washer (pos. 16) and 3/16" Screw (pos. 17) and tighten. To secure Impeller against rotation insert carefully Screwdriver (tool No. TE135A) through Impeller (pos. 4) into a hole in the Stem.
3. Reinstall Guide/Guide ring (pos. 2)
4. Mount Top cone (pos. 1). Make sure that it is in correct position over Guide/Guide ring (pos. 2). Rotate Top cone to align holes in Top cone and Stem.
5. Mount Screws (pos. 19) with a Socket wrench (tool No. TE962A).

# Maintenance and Repair (continued)

## Top Assembly

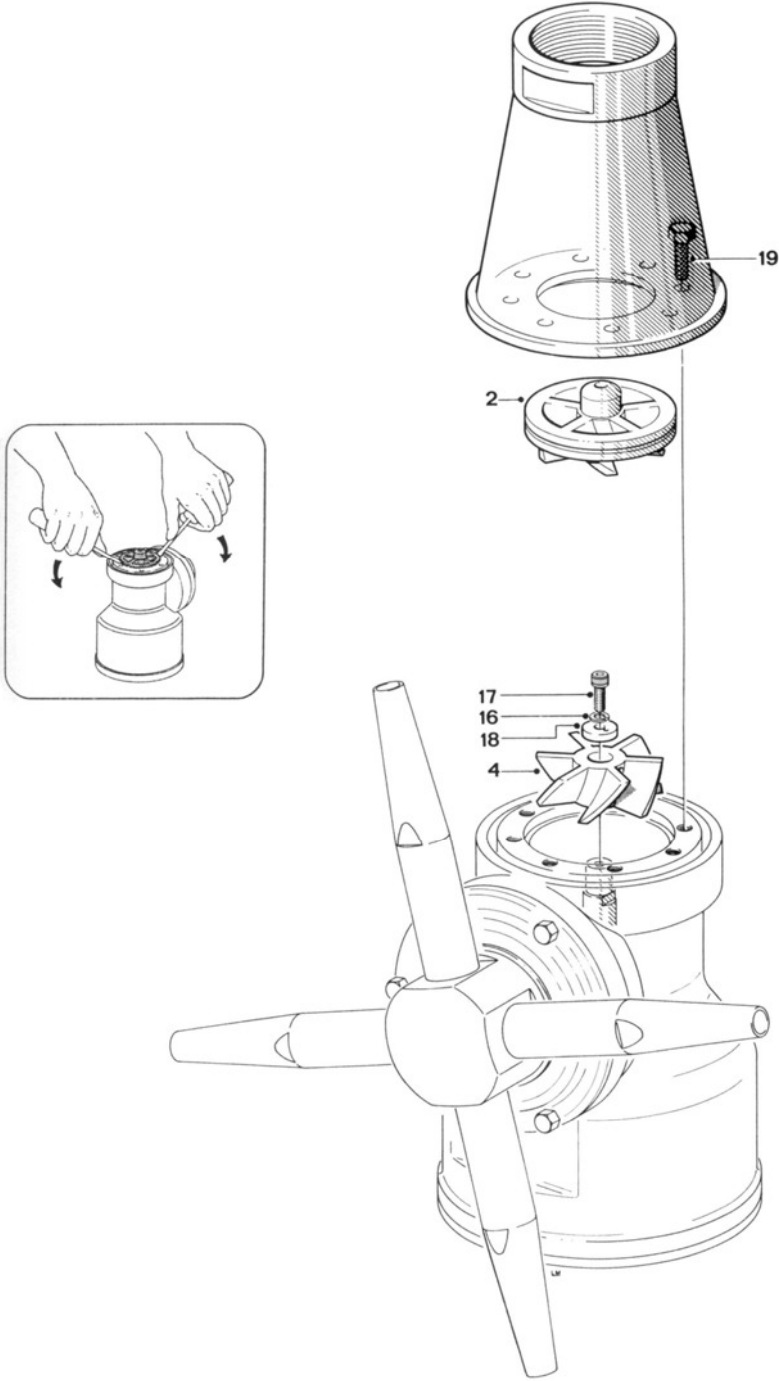

## Maintenance and Repair (continued)

### Bottom Assembly

#### Disassembly

1. Turn machine upside down.
2. Remove Screws (pos. 34) from Bottom cover (pos. 33).
3. Remove Bottom cover (pos. 33) and Gasket (pos. 35).
4. Remove Screw (pos. 17) and Spring washers (pos. 16) along the circumference of Gear frame (pos. 31). Draw out Gear Subassembly (holes in Gear frame are excellent for holding Gear subassembly).

#### Reassembly

1. Reinsert Gear subassembly in bottom of machine body. Mount Spring washers (pos. 16) and Screws (pos. 17) along circumference of Gear frame (pos. 31). Tighten screws crosswise.

**Note:** Turbine shaft is inserted carefully through Gear wheel and Stem. Note also that to secure meshing between Gear wheel (pos. 8) and Pinion (pos. 11) it might be necessary to rotate slightly either the whole Gear subassembly or the Gear wheel.

2. Replace Bottom gasket (pos. 35) and Bottom cover (pos. 33).
3. Mount Screws (pos. 34) and tighten crosswise.

# Maintenance and Repair (continued)

## Bottom Assembly

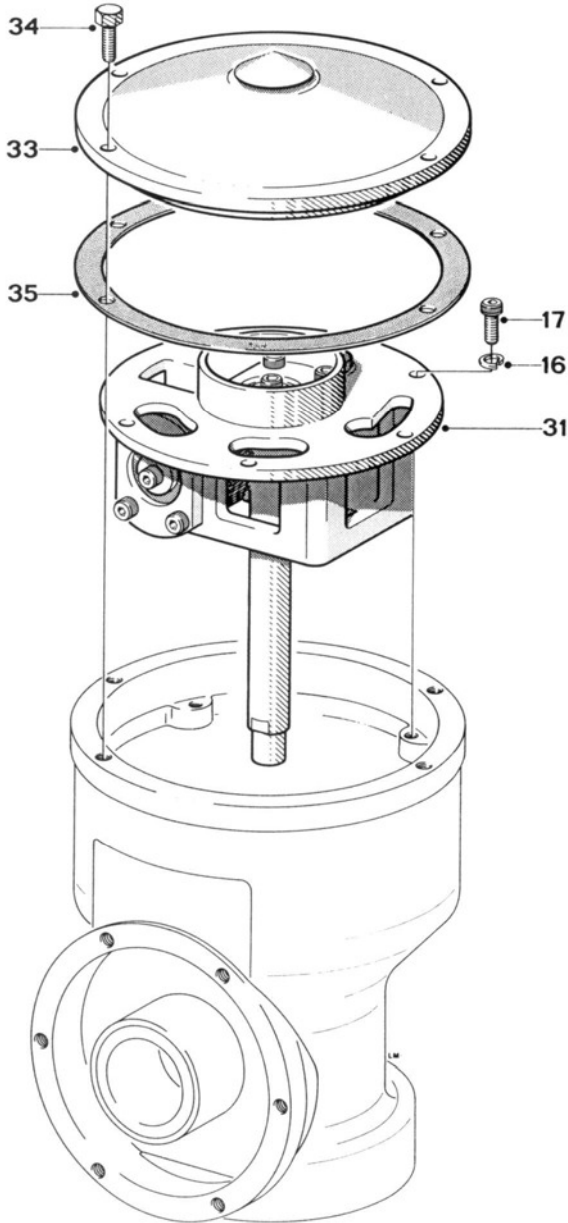

## Maintenance and Repair (continued)

### Hub Subassembly

#### Disassembly

1. Remove Nozzles (pos. 22). Nozzles are untightened with a wrench on the faces of the nozzles.
2. Remove Screws (pos. 34) from Hub cover (pos. 21).
3. Draw out Hub (pos. 23) together with Hub cover (pos. 21), Ball race (pos. 26), Hub gasket (pos. 24), Ball retainer with balls (pos. 27) and Bevel gear (pos. 20). If Hub cover (pos. 21) clings into Body, knock carefully with plastic hammer on outer diameter to loosen.

If Ball races (pos. 20.1 and 21.1) in Hub cover and in Bevel gear are extremely worn, they should be replaced as well as the Ball retainer with balls (pos. 27). How to replace Ball races see page 24.

If blue teflonliner inside Hub is extremely worn, it can be replaced. This part requires that a precise procedure is followed to accomplish installation. It is suggested that an authorized Alfa Laval Tank Equipment service center perform the replacement when necessary. However, should the customer insist that they perform the installation, please contact your nearest Service Center for a copy of the procedure.

#### Reassembly

1. Slide on Hub (pos. 23).
2. Mount Bevel gear with race (pos. 20), Ball retainer with balls (pos. 27), Hub gasket (pos. 24) and Hub cover (pos. 21) and set with Screw (pos. 34).
3. Screw on Nozzles (pos. 22) and tighten with wrench. If desired, secure with liquid threadlocker Loctite No. 243 or equivalent, see page 8-9.

# Maintenance and Repair (continued)

## Hub Assembly

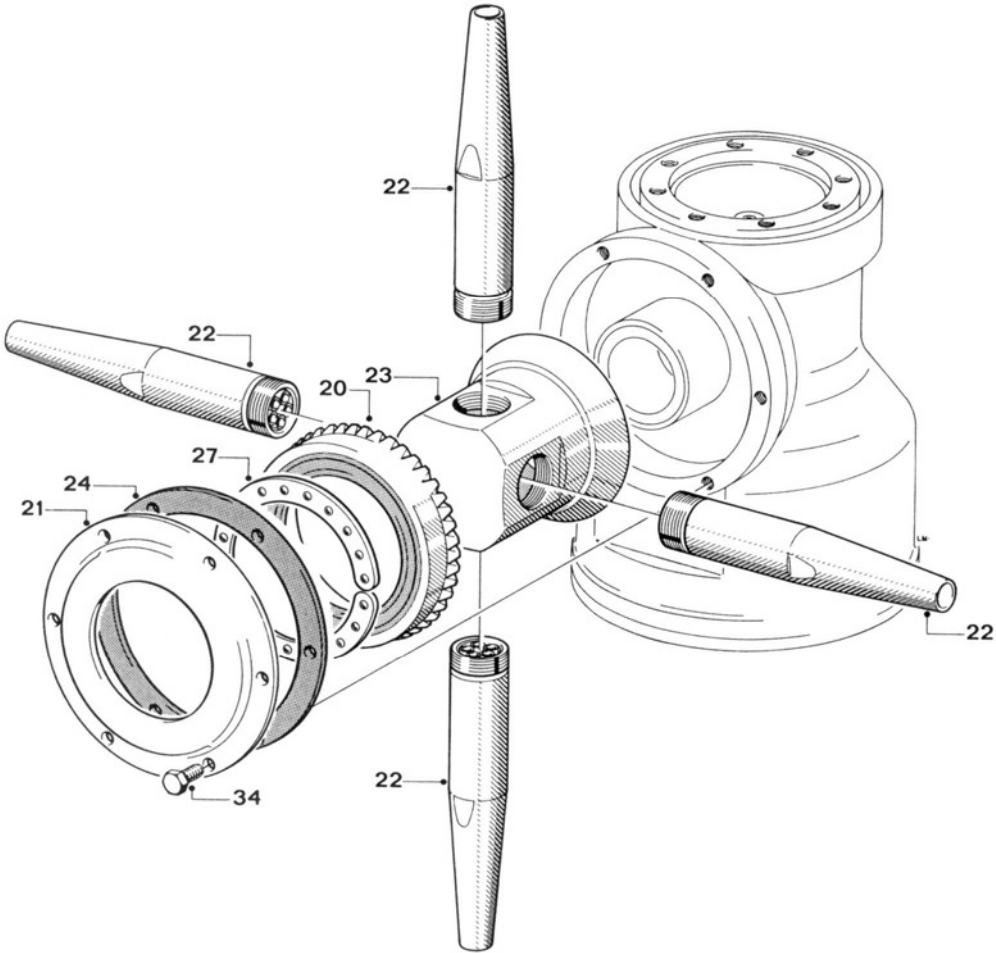

## Maintenance and Repair (continued)

### Stem Subassembly

#### Disassembly

1. Place machine in upright position.
2. Unscrew Gland (pos. 5). Note: Left-hand thread. Push out Main bush (pos. 6).
3. Turn machine upside down.
4. Remove Screws (pos. 10) in Gear wheel (pos. 8). To prevent rotation of Stem (pos. 3) mount two screws in two holes opposite one another in BIG end of Stem. Place Stem in a vice held by the heads of the two screws.
5. Draw out Gear wheel with ball race (pos. 8) and Ball retainer with balls (pos. 27).
6. Push out Stem (pos. 3).

If Ball races in Body (pos. 28.3) and on Gear wheel (pos. 8.1) are extremely worn they should be replaced together with Ball retainer with balls (pos. 27). How to replace Ball races see page 24.

If blue liners on Stem are extremely worn, they can be replaced. This part requires that a precise procedure is followed to accomplish installation. It is suggested that an authorized Alfa Laval Tank Equipment Service Center perform the replacement when necessary. However, should the customer insist that they perform the installation, please contact your nearest Service Center for a copy of the procedure.

#### Reassembly

1. Push Stem into Body. Turn machine upside-down.
2. Place Ball retainer with balls (pos. 27) and Gear wheel (pos. 8) into Body on Ball race. Rotate Gear wheel to check free rotation.
3. Mount Gear wheel (pos. 8) with Screws (pos. 10) and tighten crosswise. To prevent rotation of Stem (pos. 3) mount two screws in two holes opposite one another in BIG end of Stem. Place Stem in a vice held by the heads of the two screws.
4. Turn machine to upright position. Remount Main bush (pos. 6) in Gland (pos. 5) and screw into Stem (pos. 3). Note: Left-hand thread.

# Maintenance and Repair (continued)

## Stem Subassembly

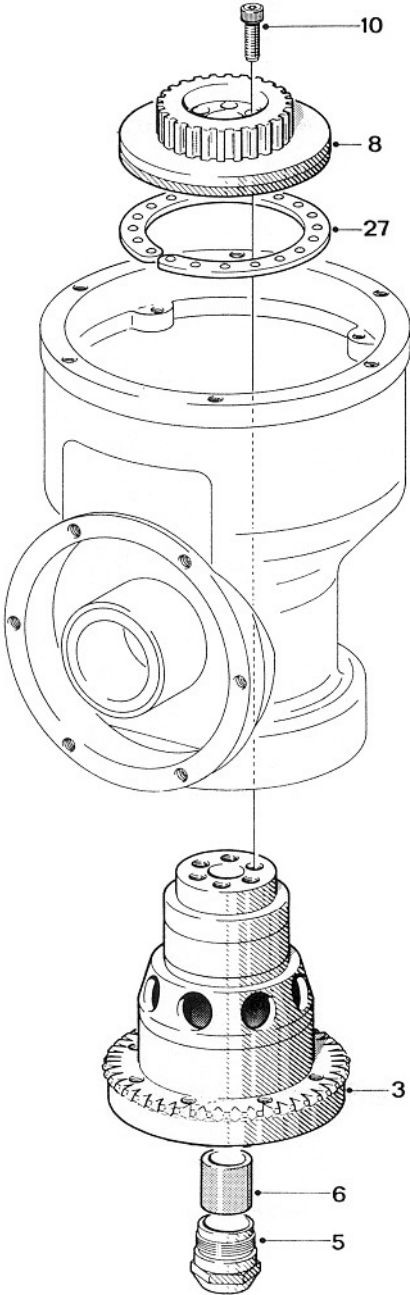

## Maintenance and Repair (continued)

### Gear Subassembly

#### Disassembly

1. Hold Turbine shaft (pos. 7) against 1st stage Worm wheel (pos. 14) with one hand and loosen Screws (pos. 17) in Pinion (pos. 11) and Horizontal shaft (pos. 29) with the other hand.
2. Draw out Turbine shaft (pos. 7) after Screw (pos. 17), Spring Washer (pos. 16) and Washer (pos. 18) has been removed. Use faces on Turbine shaft to hold against rotation.

**Warning:** Do not damage driver faces on Turbine shaft. Use only proper tools providing a firm grip such as a wrench or a vice.



3. Draw out Horizontal shaft (pos. 29) and 1st stage Worm wheel (pos. 14) after removal of Screw (pos. 17), Spring washers (pos. 16) and Washer (pos. 18).
4. Draw out Pinion (pos. 11) and 2nd stage Worm wheel (pos. 13), also freeing Journal (pos. 15) after removal of Screw (pos. 17), Spring washer (pos. 16) and Washer (pos. 18).
5. Remove Bearing covers (pos. 32) and Slide bearings (pos. 30) after removal of Screw (pos. 17).

How to replace Collar bushes (pos. 12), see page 22.

#### Reassembly

1. Push Slide bearing (pos. 30) into Gear frame (pos. 31) and fix Bearing covers (pos. 32) with Screws (pos. 17). Tighten crosswise.
2. Insert 2nd stage Worm wheel (pos. 13), Pinion (pos. 11) and Journal (pos. 15). Mount Washer (pos. 18), Spring washer (pos. 16) and fix with Screw (pos. 17). Check rotation.

**Note:** It is important that the Screw holding the Pinion is fastened to a torque moment of 5 Nm, to secure it from loosening.

## Maintenance and Repair (continued)

### Gear Subassembly

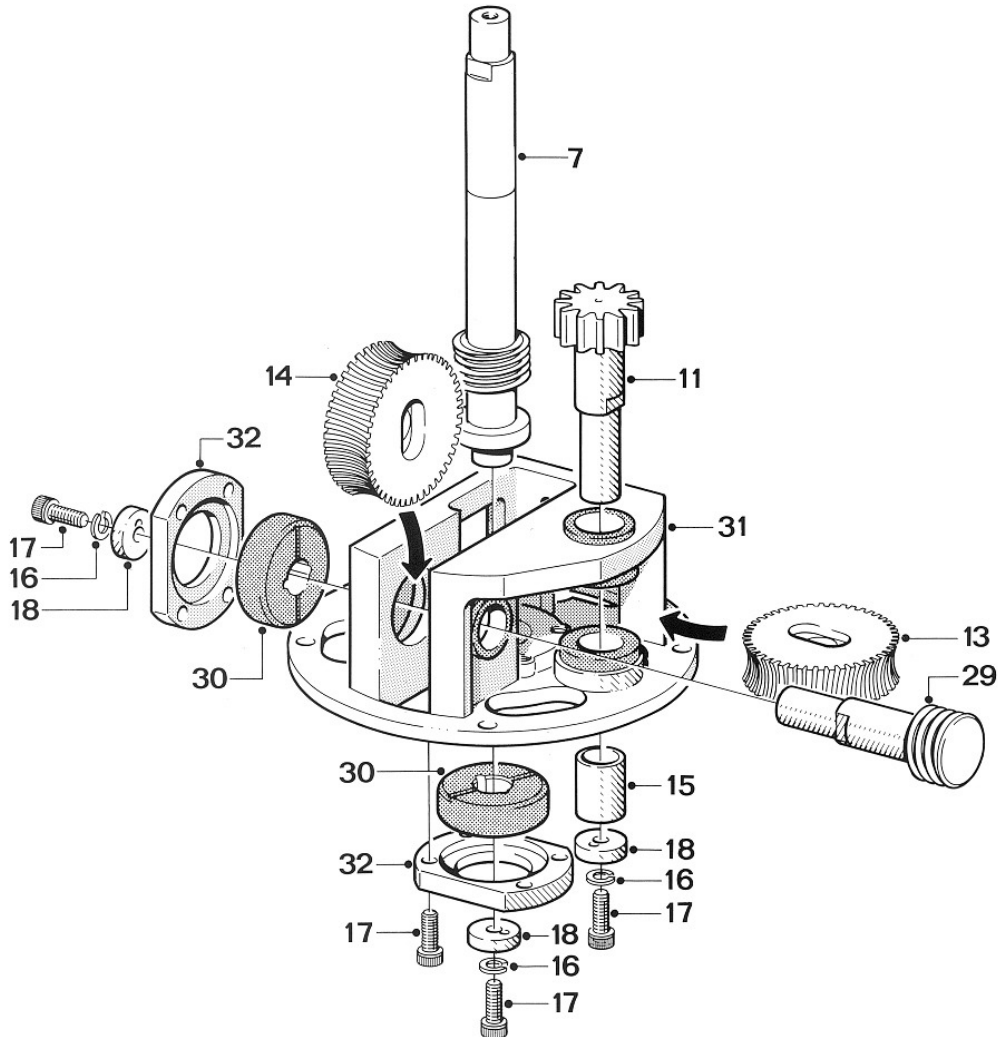

3. Insert 1st stage Worm wheel (pos. 14) and Horizontal shaft (pos. 29). Mount Washer (pos. 18), Spring washer (pos. 16) and fix with Screw (pos. 17). Check rotation.
4. Insert Turbine shaft (pos. 7). Mount Washer (pos. 18), Spring washer (pos. 16) and fix with Screw (pos. 17). Use faces on Turbine shaft to hold against rotation when tightening screw.
5. Hold Turbine shaft (pos. 7) against 1st stage Worm wheel and tighten Screws (pos. 17) in Horizontal shaft (pos. 29) and Pinion (pos. 11). Check rotation on Turbine shaft.

## Maintenance and Repair (continued)

### Replacement of Collar Bushes

1. Place Gear frame (pos. 31) upside down with a firm support under the flange. Use for instance jaws of a vice. Do not clamp on machined surfaces. With Pusher (tool no. TE81B031, see page 28) knock out Collar bush.
2. Turn Gear frame to upright position and hold over support such as flat steel bar clamped in a vice. Knock out Collar bush with Pusher.
3. Turn Gear frame 90° and hold over support. Knock out Collar bush with Pusher.

**Warning:** To avoid risk of deforming Gear frame, it is utmost important that it is supported while the Collar bushes are being knocked out.



4. Remove all remains of old Araldite etc.. Holes must be perfectly clean before mounting new Collar bushes. Rinse with chemical cleaner.
5. Coat new Collar bushes with CIBA-GEIGY two component Standard blue Araldite and push into Gear frame.
6. To hold Collar bushes in correct position, insert fixtures (tool No. TE81B032, see page 28) and let harden according to instructions.

## Maintenance and Repair (continued)

### Replacement of Collar Bushes

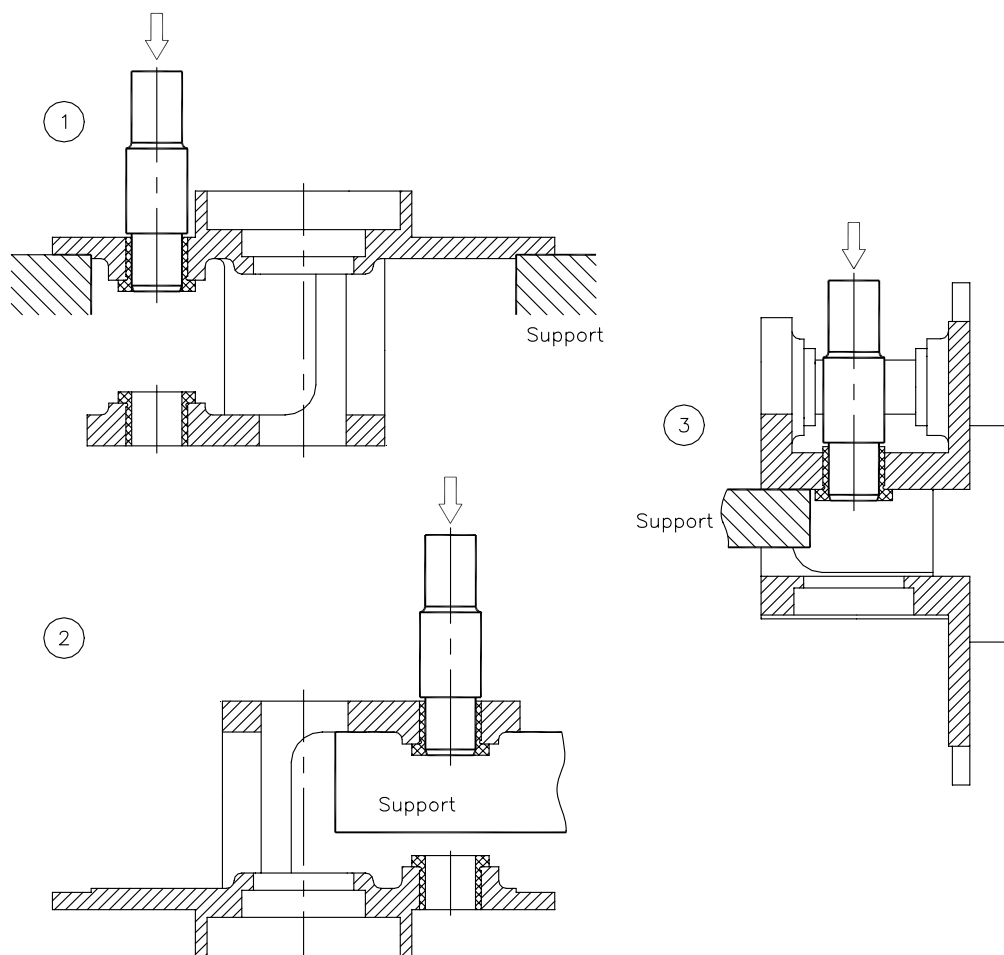

### Removal of old Collar bushes

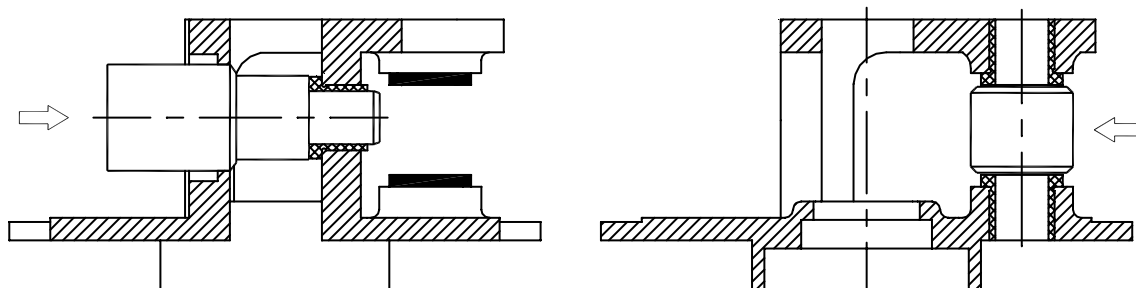

### Mounting of new Collar bushes

## Maintenance and Repair (continued)

### Replacement of Ball races

#### In Body

1. A. With big end downwards knock several times Body with bearings (pos. 28) hard against firm wooden support until Ball race (pos. 28.3) drops out.
1. B. If it is not possible to knock out Ball race in this way, it is necessary first to screw out Main collar lower (pos. 28.2) - see page 26. Carefully push off old Ball race without damaging Main collar lower. Use mandrel and firm support.

Before mounting of new Ball race, Main collar lower (pos. 28.2) must be remounted into Body - see page 26.

2. Clean surfaces and place Ball race (pos. 28.3) on Main collar lower (pos. 28.2). Press by hand as long as possible. By means of a tube mandrel or if desired wooden block, carefully hammer Ball race home.

Ball race must not project over endface of Main collar lower. To avoid tilting mandrel must push along the whole circumference of Ball race. Do not damage surface of Ball race.

#### On Gear wheel

1. Place Gear wheel with ball race (pos. 8) on support. Support only under Ball race (pos. 8.1). With mandrel press off old Ball race.
2. Clean surfaces and press on new Ball race. Ball race must be pressed fully home on Gear. Press parallel. Use press or vice. Do not damage surface of Ball race.

#### In Hub cover

1. Place Hub cover with ball race (pos. 21) on support. Carefully knock out old Ball race by means of small mandrel or if desired screwdriver. Knock several times around the circumference to avoid tilting.
2. Clean surfaces and press in new Ball race. Ball race must be pressed fully home. Press parallel. Do not damage surface of Ball race.

# Maintenance and Repair (continued)

## Replacement of Ball races

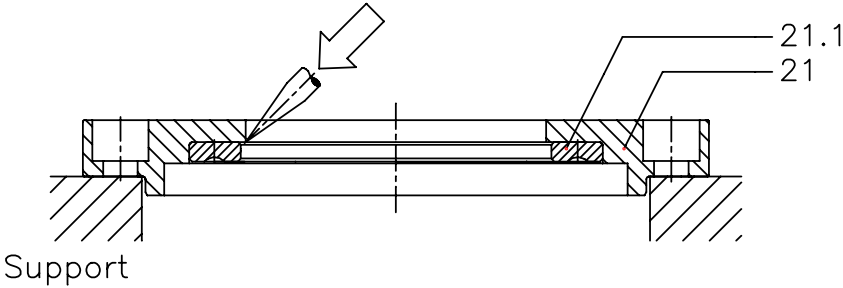
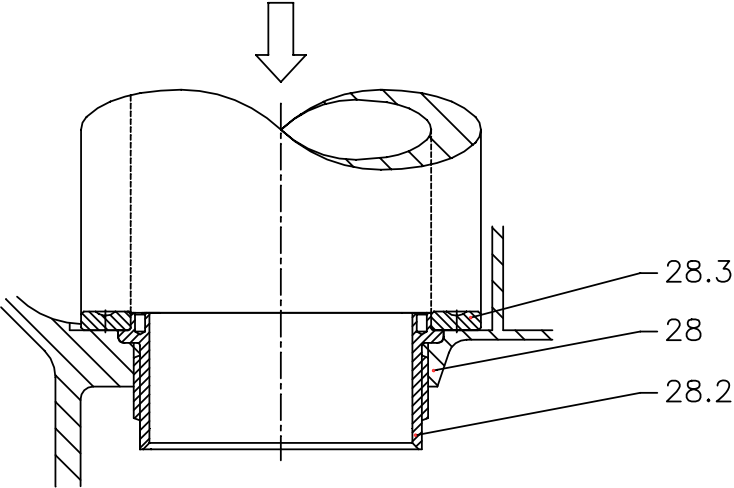
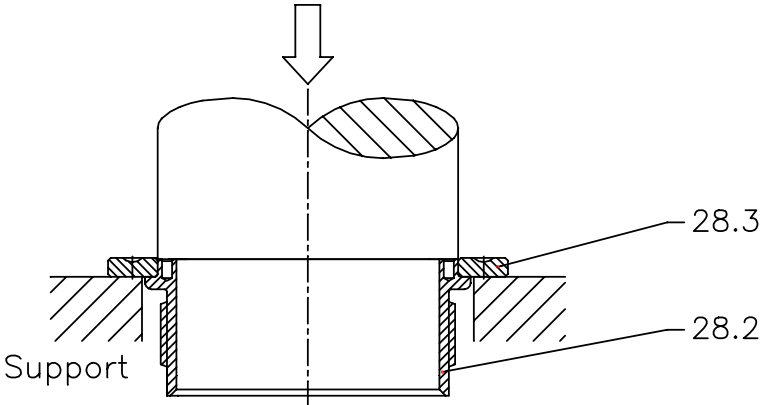

## Maintenance and Repair (continued)

### Replacement of Main Collars

Although normally exposed to very limited wear, it is possible to replace Main collars (pos. 28.1 and 28.2) in Body. The procedure to do this is described below.

**Warning:** Replacement of Main collars involves risk of damaging the special threads and accordingly the body. It is recommended to let an authorized Alfa Laval Tank Equipment sales office do the replacement.



#### Main collar upper

1. Place Body (pos. 28) in a vice in upright position. Do not clamp on machined faces. Insert Tool (see page 28) into Main collar upper (pos. 28.1). Unscrew Main collar.
2. Carefully clean thread and recess in Body. Do not damage special thread in Body. Recess must be absolutely clean.
3. Make sure that new Main collar is clean and free from impurities.
4. Screw in new Main collar. Attention should be given to make sure that thread is in correct engagement before screwing in Main collar.
5. Tighten Main collar fully home. Several times knock hard on tool and tighten up.
6. Check that main collar is fully home: Install Stem, Ball retainer with balls and Gear wheel (see page 18). Check that there is sufficient axial clearance to allow for free rotation of Stem.

#### Main Collar Lower

1. Place Body in a vice in upside down position and repeat procedure described above.

**Warning:** Thread on Main collar lower is left-handed.



# Maintenance and Repair (continued)

## Replacement of Main Collars

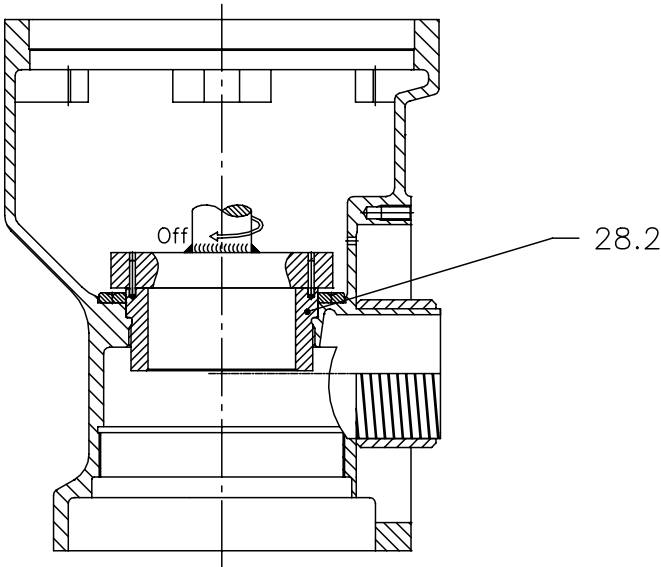
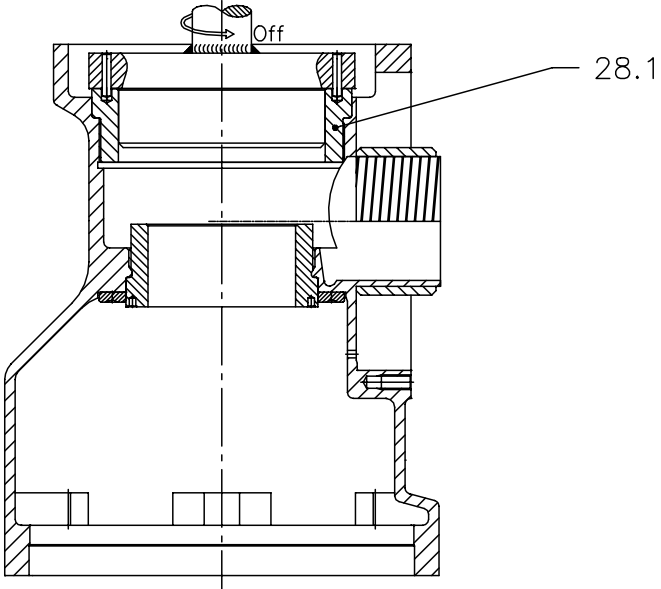

## Tools

### Standard Tool kit for Toftejorg TZ-79

#### Article no. TE81B075

Tool No.	Description	No.
TE134	Unbraco key for screw	1 pcs.
TE134A	Unbraco Screwdriver	1 pcs.
TE135	Unbraco key for screw	1 pcs.
TE135A	Unbraco screw driver	1 pcs.
TE462	Open-end spanner	1 pcs.
TE962A	Socket Wrench w. pin	1 pcs.

Available on request:

TE81B031	Pusher for Gear frame
TE81B032	Fixture set f. Gear frame

#### Sketch of Tools for replacement of Collar bush

TE81B031: Pusher for Gear frame

TE81B032: Fixture set f. Gear frame

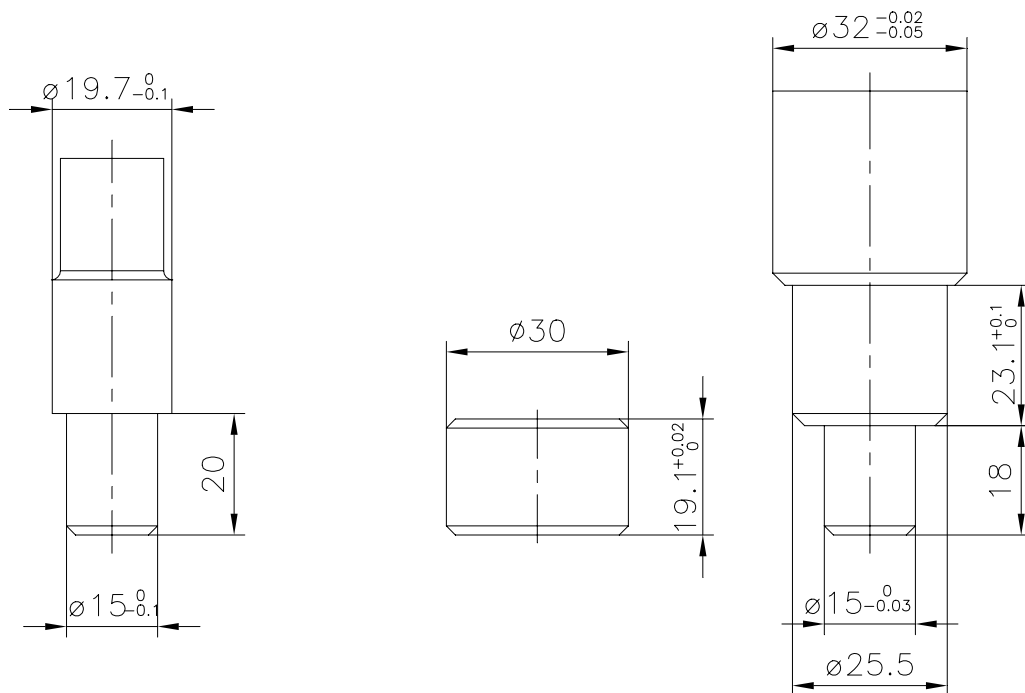

## Tools (continued)

### Sketch of tools for replacement of Main collars

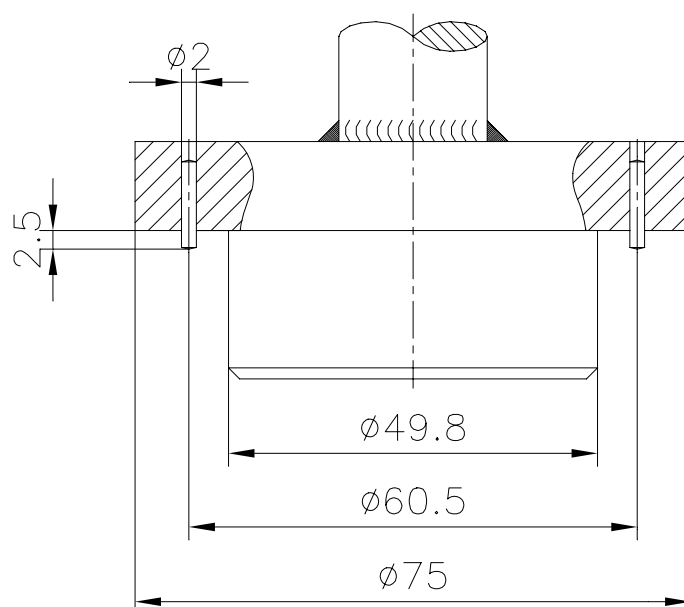
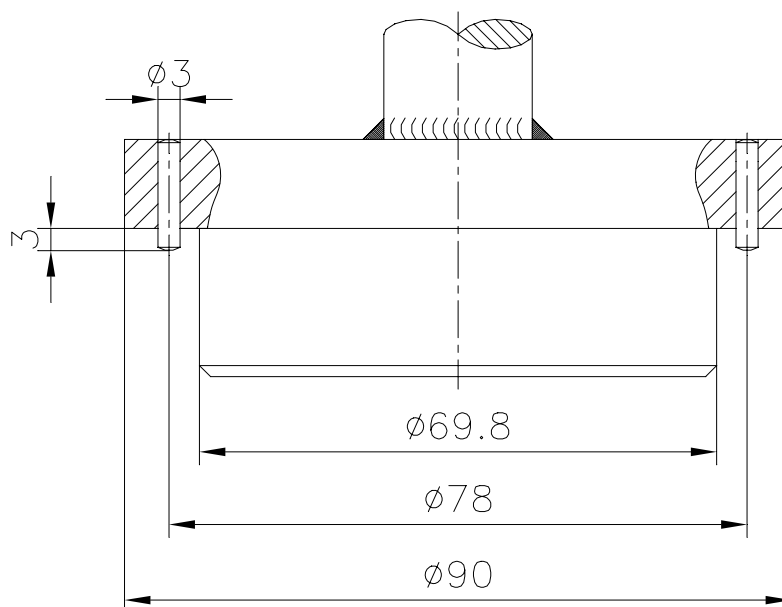

## Trouble Shooting Guide

### Symptom: Slow rotation or failure of the machine to rotate

Possible causes	Action
<b>No or insufficient liquid flow</b>	<p>a). Check if supply valve is fully open.</p> <p>b). Check if inlet pressure to machine is correct.</p> <p>c). Check supply line/filter for restrictions/clogging.</p> <p>d). Remove nozzles and check for clogging. If blocked, carefully clean nozzle without damaging stream straighteners and nozzle tip.</p> <p>e). Remove Top cone, Guide and Impeller (see page 12) and check for clogging in Impeller area.</p> <p>If large particles repeatedly get jammed in the machine, install filter or reduce mesh size of installed filter in supply line.</p>
<b>Foreign Material or Material Build-up</b>	<p>Insert hex Screwdriver in screw in top of Turbine shaft and easily turn Turbine shaft clockwise. If any resistance is recognized, disassemble machine to localize the cause:</p>
a). Impeller jammed	Remove Guide and Impeller (see page 12) and remove foreign material.
b). Turbine shaft sluggish in Main bush	Remove Gear subassembly (see page 14) and clean Main bush.
c). Bevel gears jammed	Remove Top cone and Hub Subassembly (see page 16). Clean teeth on Stem and Bevel gear.
d). Stem jammed/sluggish	Remove Gear subassembly (see page 14). Check free rotation of Stem. Remove Stem (see page 18). Remove foreign material/material build-up on Stem and inside Main Collars. Clean Ball races and Ball retainer with balls. Also clean Main bush.

## Trouble Shooting Guide (continued)

Possible causes	Action
e). Gearbox jammed/sluggish	Remove foreign material from Gearbox. Check rotation of shafts. If restriction is recognized, disassemble Gearbox (see page 20) and remove material build-up, especially on 2nd stage Worm wheel and mating Collar bushes.
f). Hub jammed/sluggish	Disassemble Hub Subassembly (see page 16). Remove foreign material inside Hub. Clean Ball races and Ball retainer with balls. Also clean nose of Body.

---

### Wear

a). Slide bearings	See page 10.
b). Main bush	See page 11.
c). Worm wheels	See page 11.
d). Collar bushes	See page 10.
e). Turbine shaft	Check clearance in Main bush and in Slide bearing. Transverse movement should not exceed 0,5 mm. Also inspect worm wheel for wear.
f). Horizontal shaft	Check clearance in Collar bushes. Transverse movement should not exceed 0.5 mm. Also inspect worm for wear.

---

### Mechanical defects

a). Worm wheel/Teeth broken	Replace Worm wheel.
b). Worm wheel can rotate on Horizontal shaft/Pinion due to damaged driver faces	Replace Worm wheel.
c). Damaged teeth on Bevel gear	Inspect teeth on Stem and Bevel gear for deformation. Mount Hub and Stem in Body (see page 16 and 18). Hold Body in upside down position and rotate Hub to check that Bevel gears can work together. If damaged: Replace Stem and/or Bevel gear.

## Reference List of Parts

Pos.	Ref. no.	No./unit	Description	Material	Remarks
1	<input type="checkbox"/> TE22D500	1	Top cone 2" BSP	Stainless steel	Spare part
	<input type="checkbox"/> TE22D501	1	Top cone 2" NPT	Stainless steel	Spare part
2	<input type="checkbox"/> TE603	1	Guide 100%	Stainless steel	Spare part
	<input type="checkbox"/> TE103-0	1	Guide ring 0%	Stainless steel	Spare part
3	TE604Z	1	Stem w. liners	Stainless steel/Polymer	Spare part
3.1	TE904-1 <sup>*)</sup>	(1)	Top liner	Polymer	Wear part
3.2	TEB604-2 <sup>*)</sup>	(1)	Bottom liner	Polymer	Wear part
4	TE605	1	Impeller 100%	Stainless steel	Spare part
5	608Z	1	Gland	Stainless steel	Spare part
6	<input type="checkbox"/> TE609P	1	Main bush	Polymer	Wear part
	<input type="checkbox"/> TE22B575	1	Main bush	Polymer	Wear part
7	TE911K	1	Turbine shaft	Stainless steel	Wear part
8	TE512-13	1	Gear wheel w. ball race	Stainless steel	Spare part
8.1	TE126-1	(1)	Ball race	Stainless steel	Wear part
10	TE120	6	Screw	Stainless steel	Spare part
11	TE114	1	Pinion	Stainless steel	Spare part
12	<input type="checkbox"/> TE615K	3	Collar bush	Carbon	Wear part
	<input type="checkbox"/> TE22A585	3	Collar bush	Polymer	Wear part
13	<input type="checkbox"/> TE22A360	1	Worm wheel w. reinforcem.	Polymer/Stainless steel	Wear part
	<input type="checkbox"/> TE22A365	1	Worm wheel w. reinforcem.	Polymer	Wear part
14	<input type="checkbox"/> TE22A360	1	Worm wheel w. reinforcem.	Polymer/Stainless steel	Wear part
	<input type="checkbox"/> TE22A365	1	Worm wheel w. reinforcem.	Polymer/Stainless steel	Wear part
15	TE117	1	Journal	Stainless steel	Spare part
16	TE156	9	Spring washer	Stainless steel	Spare part
17	TE118	17	Screw	Stainless steel	Spare part
18	TE619A	4	Washer	Stainless steel	Spare part
19	TE902H	8	Screw	Stainless steel	Spare part
20	TE622S	1	Bevel gear w. ball race	Stainless steel	Spare part
20.1	TE126-1	(1)	Ball race	Stainless steel	Wear part
21	TE22D340	1	Hub cover w. ball race	Stainless steel	Spare part
21.1	TE126-1	(1)	Ball race	Stainless steel	Wear part
22	<input type="checkbox"/> TE50B008	4	Nozzle, ø8	Stainless steel	Spare part
	<input type="checkbox"/> TE50B009	4	Nozzle, ø9	Stainless steel	Spare part
	<input type="checkbox"/> TE50B010	4	Nozzle, ø10	Stainless steel	Spare part
	<input type="checkbox"/> TE50B011	2	Nozzle, ø11	Stainless steel	Spare part
22.1	TE50B000	2	Plug	Stainless steel	Spare part
23	TE624-4KZ	1	Hub w. liner	Stainless steel	Spare part
23.1	TE624-11 <sup>*)</sup>	(1)	Hub liner	Polymer	Wear part
24	TE22D553	1	Hub gasket	Modified polymer, elastomer	Spare part
27	TE126S	2	Ball retainer w. balls	Polymer/Stainless steel	Wear part
28	TE627Z	1	Body with bearings	Stainless steel	Not available
28.1	TE127Z1	(1)	Main collar upper	Stainless steel	Wear part
28.2	TE127Z2	(1)	Main collar lower	Stainless steel	Wear part
28.3	TE126-1	(1)	Ball race	Stainless steel	Wear part
28.4	TE127-3	(1)	Hub collar	Stainless steel	Wear part
29	TE128Z	1	Horizontal shaft	Stainless steel	Wear part
30	<input type="checkbox"/> TE929K	2	Slide bearing	Carbon	Wear part
	<input type="checkbox"/> TE22A570	2	Slide bearing	Polymer	Wear part
31	TE630R	1	Gear frame w. bushes	Stainless steel/Carbon	Spare part
32	TE531	2	Bearing cover	Stainless steel	Spare part
33	TE22D350	1	Bottom cover, compl.	Stainless steel	Spare part
34	TE421H	12	Screw	Stainless steel	Spare part
35	TE22D554	1	Bottom gasket	Modified polymer, elastomer	Spare part

Configuration as delivered marked

Please note that some of the polymer parts are in PEEK. PEEK is not resistant to concentrated sulfuric acid

\*) See remarks page 16 and 18.

# Cross Sectional Drawing

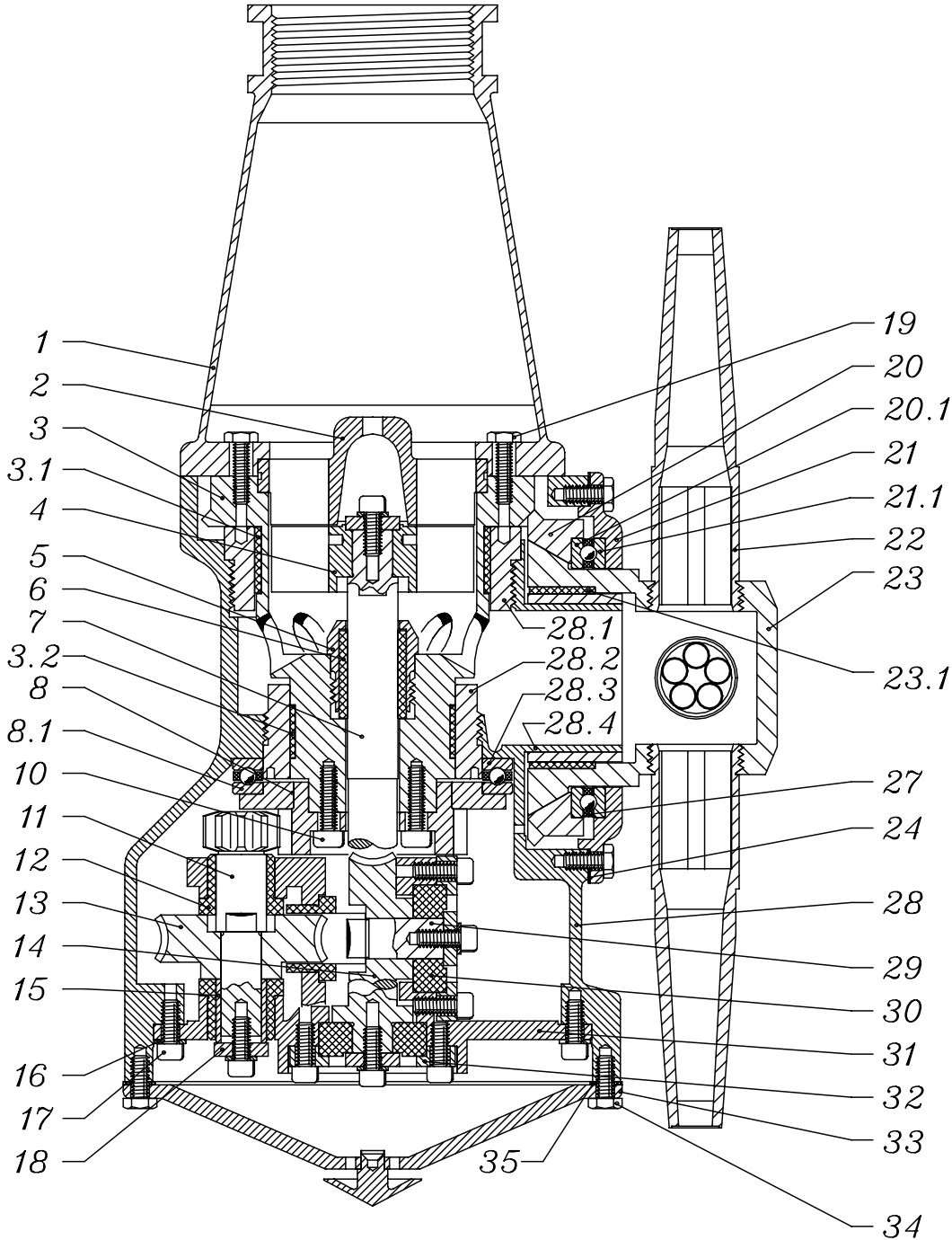

## Service Kits

### Standard Service Kit for Toftejorg TZ-79

#### Article No. TE55M000

Part No.	Description	No.
TE22A360	Worm wheel w. reinforcement	2 pcs.
TE609P	Main bush	1 pcs.
TE615K	Collar bush	3 pcs.
TE651*	Locking Wire	4 pcs.
TE929K	Slide bearing	2 pcs.

\* Locking wire only used in fixed version and can be disregarded

### Optional Service Kit for Toftejorg TZ-79 with Polymer Wear Parts

#### Article No. TE55M001

Part No.	Description	No.
TE22A365	Worm wheel w. reinforcement	2 pcs.
TE22B575	Main bush	1 pcs.
TE22A585	Collar bush	3 pcs.
TE651*	Locking Wire	4 pcs.
TE22A570	Slide bearing	2 pcs.

\* Locking wire only used in fixed version and can be disregarded

## **How to order spare parts and claim procedure**

### **How to Order Spare Parts**

On the Cross Sectional Drawing as well as on all instruction drawings, the individual parts has a pos. number which is the same on all drawings. From the pos. number, the part is easily identified in the Reference list of Parts, page 32.

Individual parts should always be ordered from the Reference list of parts, page 32. Reference number and Description should be clearly stated.

Please also quote the type of machine and serial number. This will help us to help you. The type and serial number are stamped on the Body of the tank cleaning machine.

### **Claim Procedure**

In case of failure that needs assistance from Alfa Laval Tank Equipment A/S, it is essential for our evaluation that the problem as well as the working conditions of the machine are described as detailed as possible.

For description of the working conditions, fill in copy of Claim Report - Working Conditions, which you will find at the back of this manual.

## **How to contact Alfa Laval Tank Equipment A/S**

For further information please feel free to contact:

Alfa Laval Tank Equipment A/S  
Baldershoej 19  
P.O. Box 1149  
2635 Ishoej  
Denmark

Phone no.: +45 43 55 86 00  
Fax no.: +45 43 55 86 01  
[www.alfalaval.com](http://www.alfalaval.com)  
[www.toftejorg.com](http://www.toftejorg.com)

Contact details for all countries are continually updated on our websites.



# Claim Report Working Conditions

Page 1/2

**Ref. Claim Case** : \_\_\_\_\_

**Machine/Cleaner Type** : \_\_\_\_\_ **Serial No.:** \_\_\_\_\_

Configuration

- Nozzles : \_\_\_\_\_ x  $\varnothing$  \_\_\_\_\_ mm

- Turbine/Inlet Guide : \_\_\_\_\_ %

## Working Conditions

Inlet pressure at machine/cleaner : \_\_\_\_\_

Type of Valve in inlet line : \_\_\_\_\_

Can hydraulic shock be disregarded: :  Yes  No

Inlet line flushed before installation of tank cleaner? :  Yes  No

Working hours before failure : \_\_\_\_\_ hours

## Cleaning Programme

Cleaning media and conc.	Temperature	Time	Recirculation?

Is sterilising being used? :  Yes  No

Procedure (media/temp.)? : \_\_\_\_\_

Is steam injection being used for heating? :  Yes  No

Time: \_\_\_\_\_

Temperature: \_\_\_\_\_

v. 98.1

## Claim Report Working Conditions (continued)

Page 2/2

### Condition of Cleaning Media

- |                                                                     |                                           |
|---------------------------------------------------------------------|-------------------------------------------|
| <input type="checkbox"/> Clean                                      |                                           |
| <input type="checkbox"/> Contaminated with (nature and description) |                                           |
| <input type="checkbox"/> Chemicals/Solvents _____                   | <input type="checkbox"/> High viscous     |
| <input type="checkbox"/> Soluble                                    | <input type="checkbox"/> Sticky/tenacious |
| <input type="checkbox"/> Low viscous                                | <input type="checkbox"/> Solidifying      |
| <input type="checkbox"/> Hard particles/size _____                  | <input type="checkbox"/> Crystallizing    |
| <input type="checkbox"/> Soft particles/size _____                  |                                           |

Has filter been installed in inlet line?

- |                              |    |
|------------------------------|----|
| <input type="checkbox"/> Yes |    |
| Mesh size: _____             | mm |
| <input type="checkbox"/> No  |    |

Is tank cleaner flushed with clean water after tank cleaning?

- |                              |                             |
|------------------------------|-----------------------------|
| <input type="checkbox"/> Yes | <input type="checkbox"/> No |
|------------------------------|-----------------------------|

### Type of Soilage/Tank Contents to be removed

Name, formula/concentration of material to be removed from tank : \_\_\_\_\_

What is material soluble in : \_\_\_\_\_

Nature of material:

- |                                             |                                           |                                                         |
|---------------------------------------------|-------------------------------------------|---------------------------------------------------------|
| <input type="checkbox"/> Volatile/explosive | <input type="checkbox"/> Sticky/tenacious | <input type="checkbox"/> Contains soft particles        |
| <input type="checkbox"/> Low viscous        | <input type="checkbox"/> Solidifying      | <input type="checkbox"/> Contains hard particles/fibres |
| <input type="checkbox"/> High viscous       | <input type="checkbox"/> Crystallizing    |                                                         |

Is tank cleaner submerged in material?

- |                              |                             |
|------------------------------|-----------------------------|
| <input type="checkbox"/> Yes | <input type="checkbox"/> No |
|------------------------------|-----------------------------|

### Other information/Remarks

---

---

Date: \_\_\_\_\_

Sign.: \_\_\_\_\_



