



# Instruction Manual

Toftejorg TZ-67

IM-TE91A100-EN1  
March 2005

# Contents

Contents .....	1
Introduction.....	3
General Description.....	4
Functioning .....	4
Standard configurations .....	5
Standard options .....	5
Technical data .....	6
Installation and Normal Operation.....	8
General Installation Instructions.....	8
Normal Operation.....	9
Maintenance and Repair .....	10
Preventive Maintenance.....	10
Top Assembly .....	12
Bottom Assembly .....	14
Hub Subassembly.....	16
Stem Subassembly .....	18
Gear Subassembly .....	20
Replacement of Collar Bushes.....	22
Replacement of Ball races .....	24
Replacement of Main Collars .....	26
Tools.....	28
Standard Tool kit for Toftejorg TZ-67, Article no. TE81B050 .....	28
Sketch of tools for replacement of Main collars.....	29
Trouble Shooting Guide .....	30
Reference List of Parts.....	32
Cross Sectional Drawing.....	33
Standard Service Kits and Upgrade Kits.....	34
Standard Service Kit for Toftejorg TZ-67, Article No. TE55H000.....	34
Standard Service kit for Toftejorg TZ-67, Article No. TE21B299.....	34
Upgrade Kit for Toftejorg TZ-67, Article No. TE21C285.....	34
Upgrade Kit for Toftejorg TZ-67, Article No. TE21C286.....	35
How to order spare parts and claim procedure.....	36
How to contact Alfa Laval Tank Equipment A/S.....	36
Service Card.....	37
Claim Report Working Conditions .....	38



## Introduction

This manual has been prepared as a guide for the persons who will be operating and maintaining your tank cleaning machine. The key to long life for your tank cleaning machine will always be a system of carefully planned maintenance; you will appreciate that a tank cleaning machine which has a rough and dirty job to do will need more frequent attention than one working in ideal conditions.

It is in your own interest to get the best and most economical performance from your tank cleaning machine. Neglect of maintenance means poor performance, unscheduled stoppages, shorter life and expense. Good maintenance means good performance; no unscheduled stoppages and better total economy.

You will find the information contained in this manual simple to follow, but should you require further assistance, our Customer Service Department and world-wide net of Distributors will be pleased to help you. Please quote the type and serial number with all your enquiries; this will help us to help you. The type and serial number are placed on the gear house of the tank cleaning machine.

**Note:** The illustrations and specifications contained in this manual were effective at the date of printing. However, as continuous improvement is the policy of Alfa Laval Tank Equipment, we reserve the right to alter or modify any unit specification on any product without notice or any obligation.

## General Description

The Toftejorg TZ-67 is a media driven and media lubricated tank cleaning machine. As it is self lubricating, there is no lubricating substances such as oil, grease etc. in the machine which needs to be regularly changed.

## Functioning

The flow of the cleaning fluid into the machine passes through a guide and a turbine, which is set into rotation. The turbine rotation is through a gearbox transformed into a combined horizontal rotation of the machine body and a vertical rotation of the nozzles.

The combined motion of the machine body and the nozzles ensures a fully indexed tank cleaning coverage. After  $5\frac{5}{8}$  revolutions of Hub with nozzles ( $5\frac{5}{8}$  revolutions of the machine body), one coarse cleaning pattern is laid out on the tank surface. During the following rounds, this pattern is repeated 7 times, each of which is displaced  $\frac{1}{8}$  of the mesh in the pattern. After a total of 45 revolutions of the Hub with nozzles (43 revolutions of the machine body), a complete cleaning pattern has been laid out, and the first pattern is repeated.

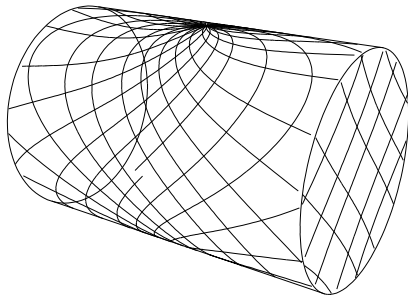

First cycle

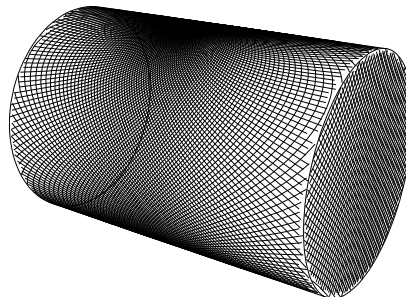

Full pattern

The speed of rotation of the turbine depends on the flow rate through the machine. The higher the flow rate is, the higher the speed of rotation will be. In order to control the RPM of the machine for a wide range of flow rates, the efficiency of the turbine can be changed (100% and 0% Turbine/Inlet guide).

Apart from the jet flow through the nozzles, fluid is leaking through the top of the machine, at the hub and through the bottom cover. The leakages between the moving parts at the top and at the hub are cleaning the gabs and thus preventing build-up of material that might cause extra friction. The flow through the bottom cover is due to the fact that the machine is media lubricated, and that accordingly a flow through the gearbox is needed.

## General description (continued)

### Standard configurations

Connection	Turbine/ Inlet Guide	Nozzles (mm) (1/2" thread connection)	Article No.
<u>Nipple:</u>			
1½" BSP, Male di: ø38	100%	4xø6	TE21C208
		4xø7	TE21C210
	0 %	4xø7	TE21C228
		4xø8	TE21C230
		2xø10	TE21C232
<u>Nipple:</u>			
1½" NPT, Male di: ø38	100%	4xø6	TE21C108
		4xø7	TE21C110
	0%	4xø7	TE21C128
		4xø8	TE21C130
		2xø10	TE21C132

The machine is equipped with a clutch in the hub, which gives the possibility of rotating by hand the nozzles, when the machine is to be lifted out through a tank opening.

### Standard options

Special options are available with hub deflector for direction of cleaning 180° upwards or downwards:

Article No.:

180° upwards: Standard article No. -04

180° downwards: Standard article No. -03

## Technical data

Weight of machine	:	6,5 kgs (14,3 lb)
Working pressure	:	2-12 bar (30-175 psi)
Recommended inlet pressure	:	3-8 bar (45-120 psi)
Working temperature max.	:	95° (200° F)
Materials	:	Stainless steel AISI 316/316L, Tefzel 200, PEEK, A4, bronze, ACO212CF

## Principal dimensions in mm

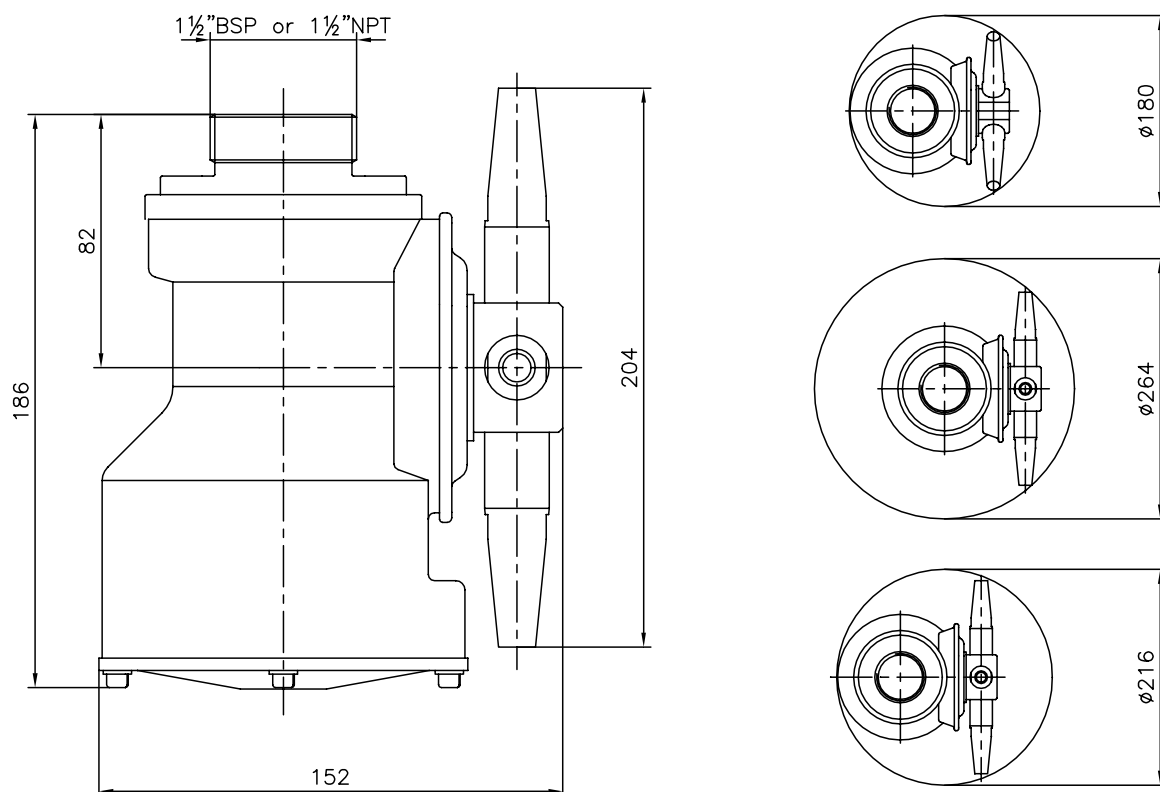

## Technical data (continued)

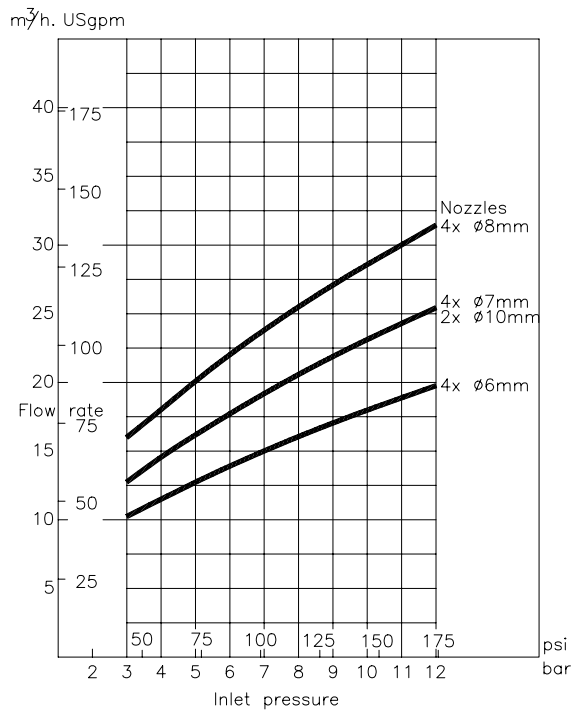

Flow rate

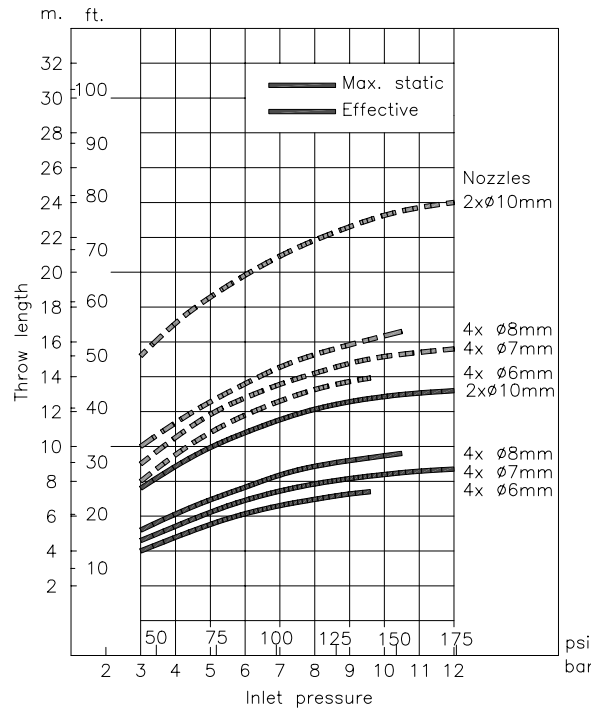

Throw length

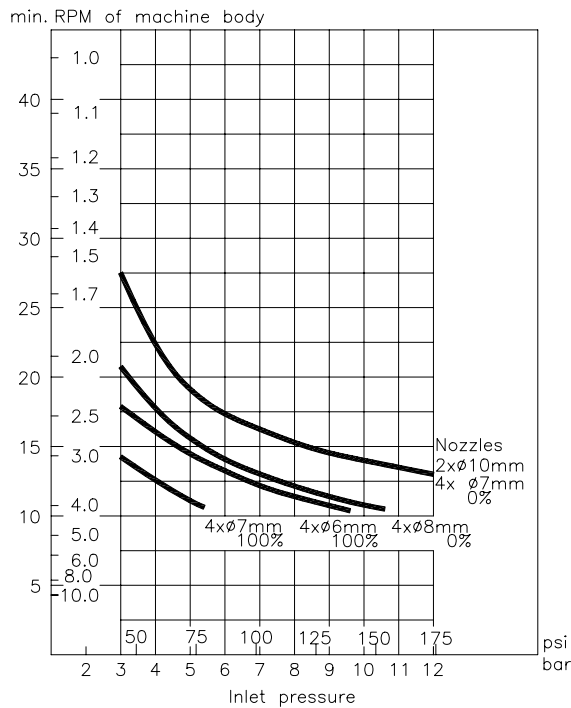

Cleaning Time f. complete Pattern (= 8 cycles)

**Note:** Throw lengths are measured as horizontal throw length at static condition. Vertical throw length upwards is approx. 1/3 less.

Effective throw length is defined as impact centre of jet 250 mm water column (50 lbs/sq.ft). Effective throw length varies depending on jet transverse speed over surface, substance to be removed, cleaning procedure and agent.

The inlet pressure has been taken immediately before the machine inlet. In order to achieve the performance indicated in the curves, the pressure drop in the supply lines between pump and machine must be taken into consideration

# Installation and Normal Operation

## General Installation Instructions

The tank cleaning machine should be installed in vertical position (upright or upside down). It is recommended to install a filter in the supply line in order to avoid large particles to clog inside the machine. Before connecting the machine into the system, all supply lines and valves should be flushed to remove foreign matter.

**Note:** The machine shall be installed in accordance with national regulations for safety and other relevant regulations and standards.

Precautions shall be made to prevent starting of the cleaning operation, while personnel are inside the tank or otherwise can be hit by jets from the nozzles.

In EU-countries the complete system must fulfil the EU-machine directive and shall be CE-marked.

**Warning:**



If the machine is used in potential explosive atmospheres, tapes or joint sealing compounds which are electrical insulators must not be used on threads or joints, unless an electrical connection is otherwise established to ensure an effective earthing. In addition, connecting pipe work, must be electrically conductive and earthed to the tank structure. The resistance between the nozzles and the tank structure should not exceed 20,000 Ohm. This is essential to avoid the build-up of static electricity on the machine.

For further information see CENELEC R044-001 Safety of Machinery, guidance and recommendations for the avoidance of hazards due to static electricity.

To protect your tank coating it is recommended to mount bumpers on the tank cleaning machine.

The machine as delivered has been tested at the factory before shipping. For transportation reasons, the nozzles have been screwed off after the test. In order to secure the nozzles against falling off due to vibrations and other external strains it is important that the nozzles are tightened properly after mounting. If not, the nozzles may be blown off during tank cleaning and cause severe damage on tank, valves and pump. This is especially important if machines are fixed installed in tanks and vessels within the transportation sector in trucks, railcars and onboard ships.

Normally, it is sufficient to tighten the nozzles with the specified torque. However, depending on the application and local policies an extra securing may be preferred.

Subject to the intended use, environment and any inhouse user requirements or policies, a liquid threadlocker such as Loctite No. 243 or equivalent could be used. Other methods could be acceptable and subject to customer preference. For detailed instruction on pre-cleaning and application of the product carefully follow the instruction on the used locking system.

## Installation and Normal Operation (continued)

1. Clamp machine firmly in a vice. Protect machine with rubber pad under the machine and use rubber jaws on the vice. Mount jaws upside down to ensure firm grip on the machine. Set torque wrench at the specified tightening torque.
2. Hold one nozzle with flat spanner to counteract while tightening the opposite nozzle with the torque wrench.

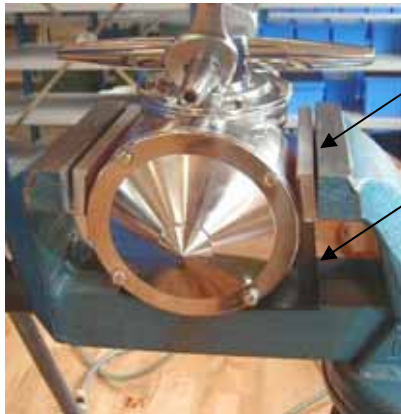

Rubber jaw mounted upside down

Protect with rubber pad



Recommended tightening torque: 40 Nm

3. Check that the machine is in operating condition by inserting hex Screwdriver (tool No. TE134A) in screw in top of Turbine shaft and easily turn Turbine shaft clockwise. If any resistance is recognised, the machine should be disassembled to localise the cause.

## Normal Operation

### Cleaning Media

Use only media compatible with stainless steel AISI 316/316L, Tefzel 200, A4, bronze, ACO212CF and PEEK. Please note that PEEK is not resistant to concentrated sulfuric acid. Normal detergents, moderate solutions of acids and alkalis will be acceptable. Aggressive chemicals, excessive concentrations of chemicals at elevated temperatures, as well as certain hypochlorites should be avoided. If you are in doubt, contact your local Alfa Laval Tank Equipment sales office.

### After Use Cleaning

After use flush the machine with fresh water. Cleaning solutions should never be allowed to dry or set-up in the system due to possible "salting out" or "scaling" of the cleaning ingredient. If cleaning media contains volatile chloride solvents, it is recommended not to flush with water after use, in case this can create hydrochloric acid.

### Pressure

Avoid Hydraulic shocks. Put on pressure gradually. Do not exceed 12 bar inlet pressure. Recommended inlet pressure appears from Technical Data (page 6-7). High pressure in combination with high flow rate will increase consumption of wear parts.

## Maintenance and Repair

### Preventive Maintenance

In order to keep your tank cleaning machine servicing you as an efficient tool in your tank cleaning operations, it is essential to maintain its high performance by following a simple preventive maintenance programme, which will always keep your tank cleaning machine in good condition.

Good maintenance is careful and regular attention!

The following recommended preventive maintenance is based on tank cleaning machines working in average conditions. However, you will appreciate that a tank cleaning machine, which has a rough and dirty job to do, will need more frequent attention than one working in ideal conditions. We trust that you will adjust your maintenance programme to suit.

Always use only proper tools. Use Toftejorg TZ-67 standard tool kit. Never force, hammer or pry components together or apart. Always perform all assembly/disassembly steps in the order described in this manual.

Never assemble components without previous cleaning. This is especially important at all mating surfaces. Work in a clear well lighted work area.

### Every 300 working hours

1. Disassemble machine as described on the following pages.
2. Clean material build-up and deposits from internal parts with Scotch-brite, S-Ultrafine, eventually chemical cleaner and fine abrasive cloth.
3. Check Slide bearings (pos. 28) for wear. If hole is worn oval to max. diameter more than 10.4 mm, Slide bearing should be replaced. If endface of Slide bearing is worn more than x mm into Slide bearing, it should be replaced.

Under Turbine shaft:  $x = 1.5 \text{ mm}$

At Horizontal shaft:  $x = 0.5 \text{ mm}$

4. Check Collar bushes (pos. 10) in Gear frame. If holes are worn oval to max. diameter more than 13.4 mm, Collar bush should be replaced. How to replace Collar bushes, see page 22.

**Note:** Timely replacement of slide bearings and collar bushes will prevent costly damage to the gearbox.

## **Maintenance and Repair (continued)**

### **Preventive Maintenance**

5. Check Worm wheels (pos. 11 and pos. 33). If extremely worn, they should be replaced.
6. Check Main bush (pos. 5). If worn it should be replaced.
7. Assemble machines as described in the following pages.
8. Check that the machine is in operating condition by inserting hex Screwdriver (tool No. TE134A) in screw in top of Turbine shaft and easily turn Turbine shaft clockwise. If any resistance is recognized, the machine should be disassembled to localize the cause.

Apart from the parts specifically mentioned above, all the remaining wear parts should regularly be inspected for wear. Which parts that are wear parts appear from Reference List of Parts, page 32.

### **Service Card**

For your registration of maintenance carried out, fill in service card which you will find at the back of this manual (see page 37).

## Maintenance and Repair (continued)

### Top Assembly

#### Disassembly

1. Remove Screws (pos. 15). Loosen with Key (tool No. TE134) and unscrew with Screwdriver (tool No. TE134A).
2. Lift off Nipple (pos. 1).
3. Remove Guide/Guide ring (pos. 2). The Guide has a groove in the outer diameter. The Guide is easily lifted out of the Stem by means of two ordinary Screwdrivers inserted into the groove.
4. Remove Screw (pos. 15), Spring washer (pos. 16) and Washer (pos. 13). To secure Impeller against rotation, insert carefully Screwdriver (tool no. TE134A), through Impeller (pos. 4) into a hole in the Stem.
5. Pull off Impeller (pos. 4).

#### Reassembly

1. Reinstall Impeller (pos. 4). Make sure that Impeller is correctly rotated to be pushed onto Turbine shaft. Do not try to hammer Impeller in position, as this will damage Slide bearing under Turbine shaft.
2. Mount Washer (pos. 13), Spring washer (pos. 16) and Screw (pos. 15) and tighten. To secure Impeller against rotation insert carefully Screwdriver (tool No. TE134A) through Impeller (pos. 4) into a hole in the Stem.
3. Reinstall Guide/Guide ring (pos. 2)
4. Mount Nipple (pos. 1). Make sure that it is in correct position over Guide/Guide ring (pos. 2). Rotate Nipple to align holes in Nipple and Stem.
5. Mount Screws (pos. 15) with Screwdriver (tool No. TE134A). Tighten with Key (tool No. TE134).

# Maintenance and Repair (continued)

## Top Assembly

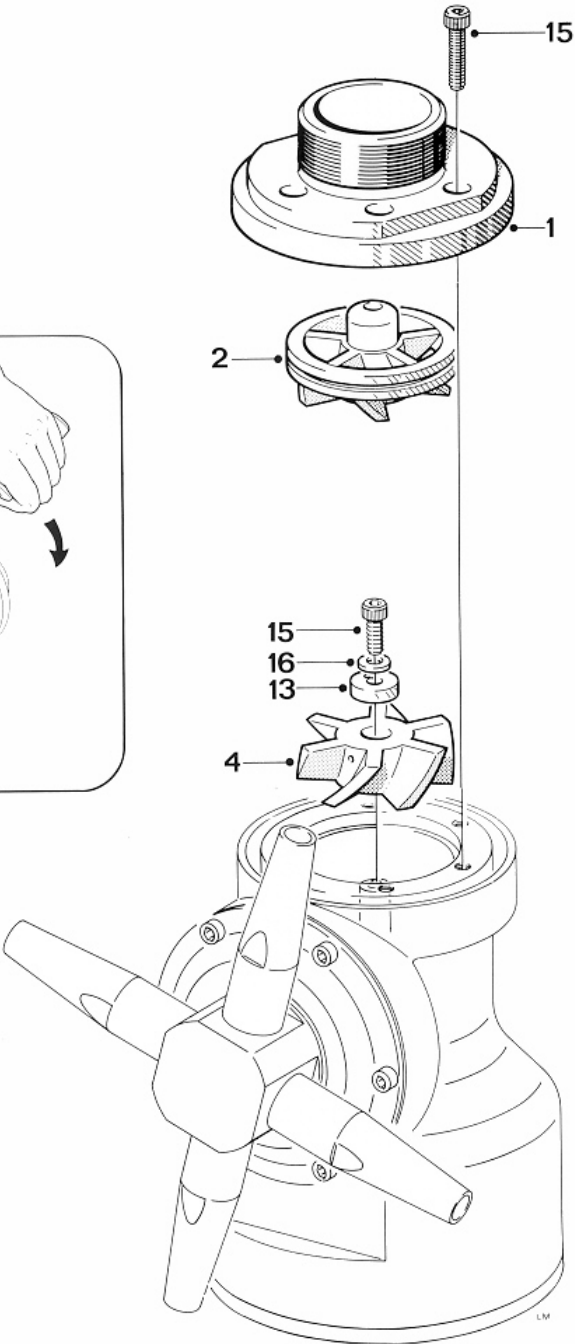

## Maintenance and Repair (continued)

### Bottom Assembly

#### Disassembly

1. Turn machine upside down.
2. Remove Screws (pos. 15) and Spring washer (pos. 16) from Bottom cover (pos. 30).
3. Remove Bottom cover (pos. 30)
4. Remove Screws (pos.15) in Bearing cover (pos. 14). Carefully push out Turbine shaft (pos. 6) from opposite end. Do not try to hammer out Turbine shaft, since this can damage Slide bearing.
5. Remove Screw (pos. 15) and Spring Washers (pos. 16) along the circumference of Gear frame (pos. 29). Turn Gear frame clockwise about 1 cm ( $\frac{1}{2}$ "). Draw out Gear Subassembly (holes in Gear frame are excellent for holding Gear Subassembly).

#### Reassembly

1. Reinsert Gear subassembly in bottom of machine body. Turn Gear Frame (pos. 29) to align holes in Gear frame and 3/16" threads in body. Mount Spring washers (pos. 16) and Screws (pos. 15) along circumference of Gear frame (pos. 29). Tighten screws crosswise.

**Note:** To secure meshing between Gear wheel (pos. 7) and Pinion (pos. 9), it might be necessary to rotate slightly either the whole Gear Subassembly or the Gear wheel.

2. Reinsert Turbine shaft (pos. 6) with Slide bearing carefully through Gear wheel (pos. 7). Push carefully Slide bearing (pos. 28) into position. Mount Bearing cover (pos. 14) with Screws (pos. 15). Tighten crosswise.
3. Place Bottom cover (pos. 30).
4. Mount Spring washers (pos. 16) and Screws (pos. 15) and tighten crosswise.

**Maintenance and Repair (continued)**

**Bottom Assembly**

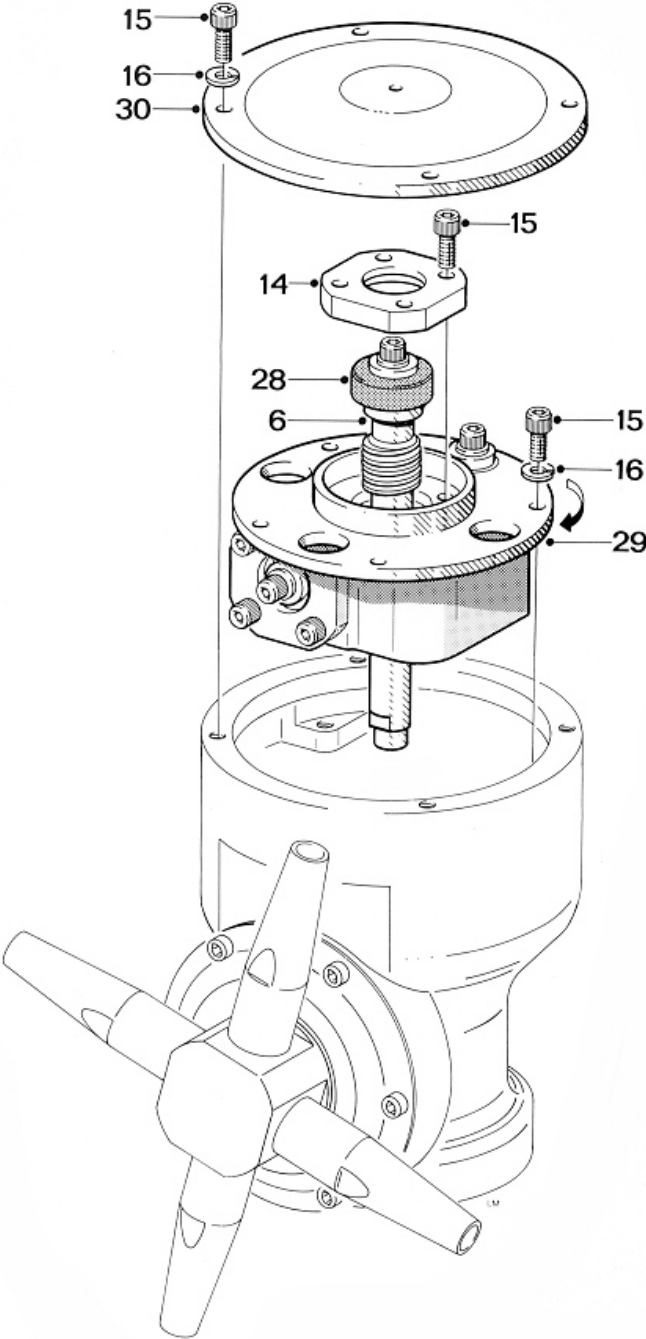

## Maintenance and Repair (continued)

### Hub Subassembly

#### Disassembly

1. Remove Nozzles (pos. 20). Nozzles are untightened with a wrench on the faces of the nozzles.
2. Remove Screws (pos. 16) and Spring washers (pos. 16) and Hub cover (pos. 19).
3. Draw out Hub (pos. 21) together with Ball retainer with balls (pos. 24) and Bevel gear (pos. 18).

If Ball races in Hub cover (pos. 19.1) and in Bevel gear (pos. 18.1) are extremely worn, they should be replaced as well as the Ball retainer with balls (pos. 24). How to replace Ball races see page 24.

4. Remove Lipseal (pos. 22) and check for wear. If the Lipseal is worn, it has to be replaced.

#### Reassembly

1. Mount the Lipseals (pos. 22).
2. Slide on Hub (pos. 21). Reinsert Bevel gear with race (pos. 18) and Ball retainer with balls (pos. 24).
3. Mount Hub cover with race (pos. 19), and set with Spring washers (pos. 16) and Screw (pos. 15).
4. Screw on Nozzles (pos. 20) and tighten with wrench. If desired, secure with liquid threadlocker Loctite no. 243 or equivalent, see page 8-9.

**Maintenance and Repair (continued)**

**Hub Assembly**

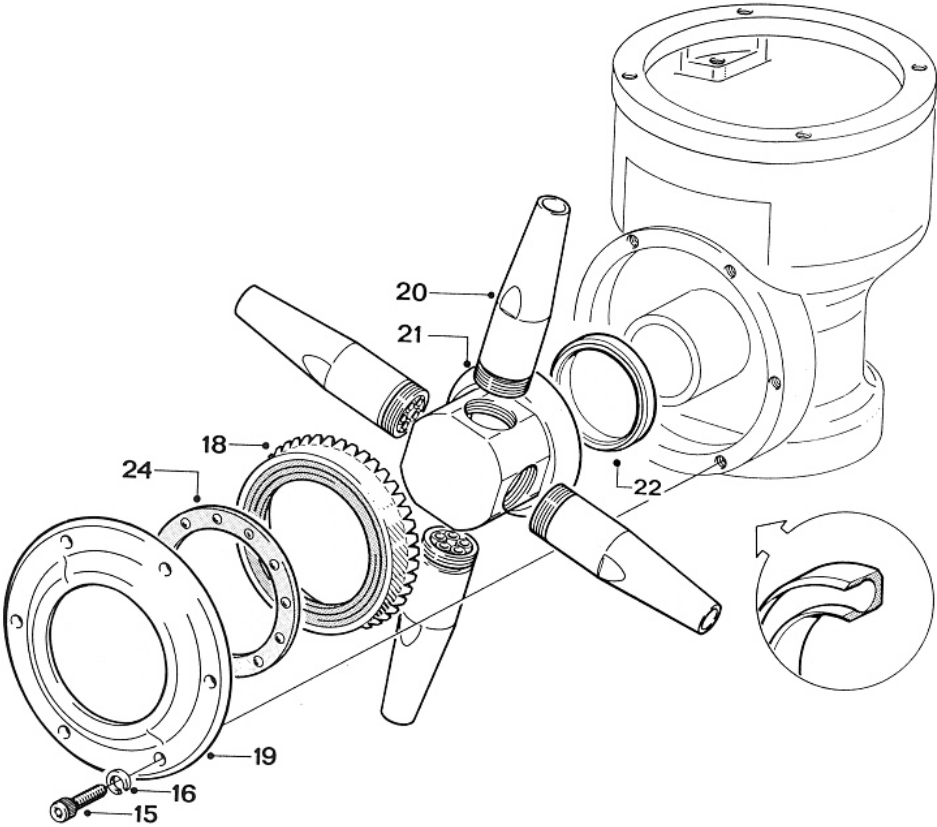

## Maintenance and Repair (continued)

### Stem Subassembly

#### Disassembly

1. Place machine in upside-down position.
2. Remove Screws (pos. 15) in Gear wheel (pos. 7). To prevent rotation of Stem (pos. 3) mount two screws in two holes opposite one another in BIG end of Stem. Place Stem in a vice held by the heads of the two screws.
3. Draw out Gear wheel with ball race (pos. 7) and Ball retainer with balls (pos. 24).
4. Push out Stem (pos. 3).
5. If worn, press out Main bush (pos. 5).

If Ball races in Body (pos. 26.3) and on Gearwheel (pos. 7.1) are extremely worn they should be replaced together with Ball retainer with balls (pos. 24). How to replace Ball races see page 24.

#### Reassembly

1. If replaced, press Main bush (pos. 5) into Stem (pos. 3).
2. Push Stem into Body. Turn machine upside-down.
3. Place Ball retainer with balls (pos. 24) and Gearwheel (pos. 7) into Body on Ball race. Rotate gearwheel to check free rotation. Mount Gearwheel with Screws (pos. 15) and tighten crosswise. To prevent rotation of Stem (pos. 3) mount two screws in two holes opposite one another in BIG end of Stem. Place Stem in a vice held by the heads of the two screws.

# Maintenance and Repair (continued)

## Stem Subassembly

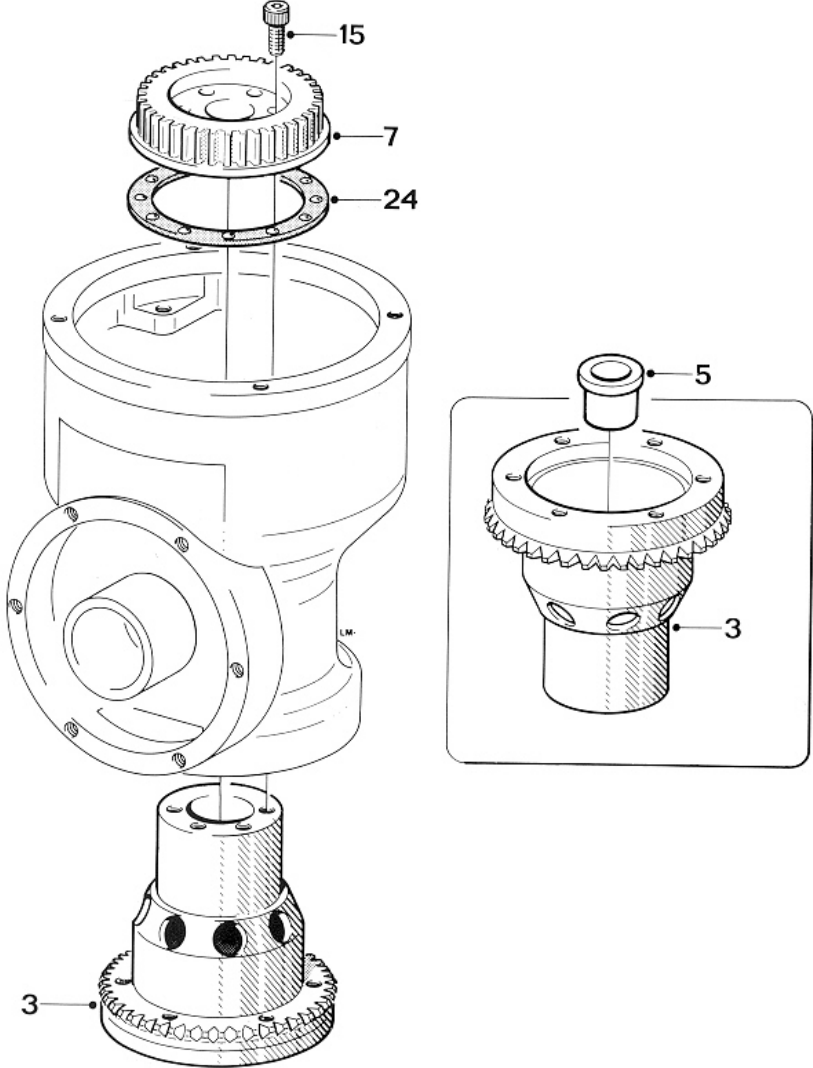

## Maintenance and Repair (continued)

### Gear Subassembly

#### Disassembly

1. To make a backstop, remount Turbine shaft (pos. 6) with Slide bearing (pos. 28) into Gear frame (pos. 29). Mount Bearing cover (pos. 14) with Screws (pos. 15).
2. Hold Turbine shaft (pos. 6) against 1st stage Worm wheel (pos. 33) with one hand and loosen Screws (pos. 15) in Pinion (pos. 9) and Horizontal shaft (pos. 27) with the other hand.
3. Remove Screws (pos. 15) in Bearing cover (pos. 14) and take out Turbine shaft (pos. 6).
4. Draw out Horizontal shaft (pos. 27) and 1st stage Worm wheel (pos. 33) after removal of Screw (pos. 15), Spring washers (pos. 16) and Washer (pos. 13).
5. Draw out Pinion (pos. 9) and 2nd stage Worm wheel (pos. 11), also freeing Journal (pos. 12) after removal of Screw (pos. 15), Spring washer (pos. 16) and Washer (pos. 13).
6. Remove Bearing cover (pos. 14) and Slide bearing (pos. 28) after removal of Screw (pos. 15).
7. Remove Screw (pos. 15), Spring washer (pos. 16), Washer (pos. 13) and Slide bearing (pos. 28) from Turbine shaft (pos. 6). Use faces on Turbine shaft to hold against rotation.

**Warning:**



Do not damage driver faces on Turbine shaft. Use only proper tools providing a firm grip such as a wrench or a vice.

How to replace Collar bushes (pos. 10), see page 22.

#### Reassembly

1. Mount Slide bearing (pos. 28) on Turbine shaft (pos. 6) and secure with Washer (pos. 13), Spring washer (pos. 16) and Screw (pos.15). Hold Turbine shaft in a vice or with wrench on driver faces and tighten screw.
2. Push Slide bearing (pos. 28) for Horizontal shaft (pos. 27) into Gear frame (pos. 29) and fix Bearing cover (pos. 14) with Screws (pos. 15). Tighten crosswise.

## Maintenance and Repair (continued)

### Gear Subassembly

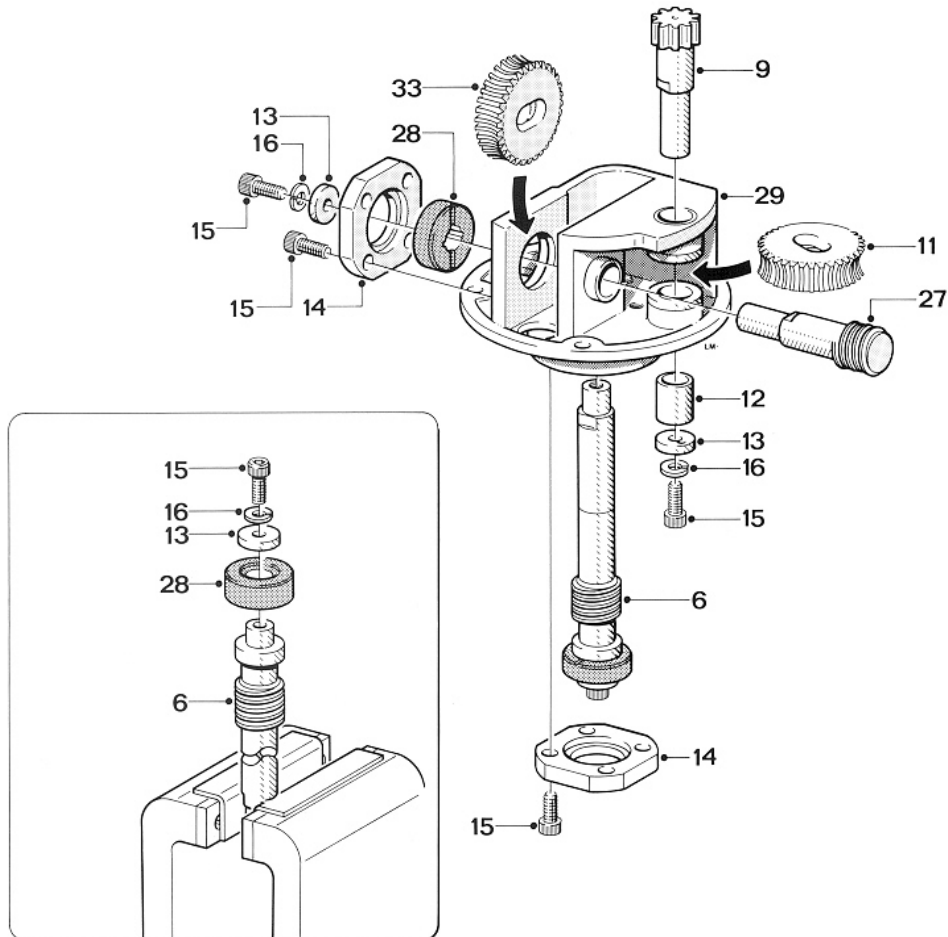

3. Insert 2nd stage Worm wheel (pos. 11), Pinion (pos. 9) and Journal (pos. 12). Mount Washer (pos. 13) Spring washer (pos. 16) and fix with Screw (pos. 15). Check rotation.
4. Insert 1st stage Worm wheel (pos. 33) and Horizontal shaft (pos. 27). Mount Washer (pos. 13) Spring washer (pos. 16) and fix with Screw (pos. 15). Check rotation.
5. Reinstall Turbine shaft (pos. 6) in Gear frame as mentioned under Disassembly, point 1.
6. Hold Turbine shaft (pos. 6) against 1st stage Worm wheel and tighten Screws (pos. 15) in Horizontal shaft (pos. 27) and Pinion (pos. 9).
7. Remove Turbine shaft (pos. 6) with Slide bearing (pos. 28) before Gear subassembly is inserted in machine body.

## Maintenance and Repair (continued)

### Replacement of Collar Bushes

1. Place Gear frame (pos. 29) upside down with a firm support under the flange. Use for instance jaws of a vice. Do not clamp on machined surfaces. With Pusher (tool no. TE81B033, see page 28) knock out Collar bush.
2. Turn Gear frame to upright position and hold over support such as flat steel bar clamped in a vice. Knock out Collar bush with Pusher.
3. Turn Gear frame 90° and hold over support. Knock out Collar bush with Pusher.

**Warning:** To avoid risk of deforming Gear frame, it is utmost important that it is supported while the Collar bushes are being knocked out.



4. Clean holes and push in new Collar bush into Gear frame.

# Maintenance and Repair (continued)

## Replacement of Collar Bushes

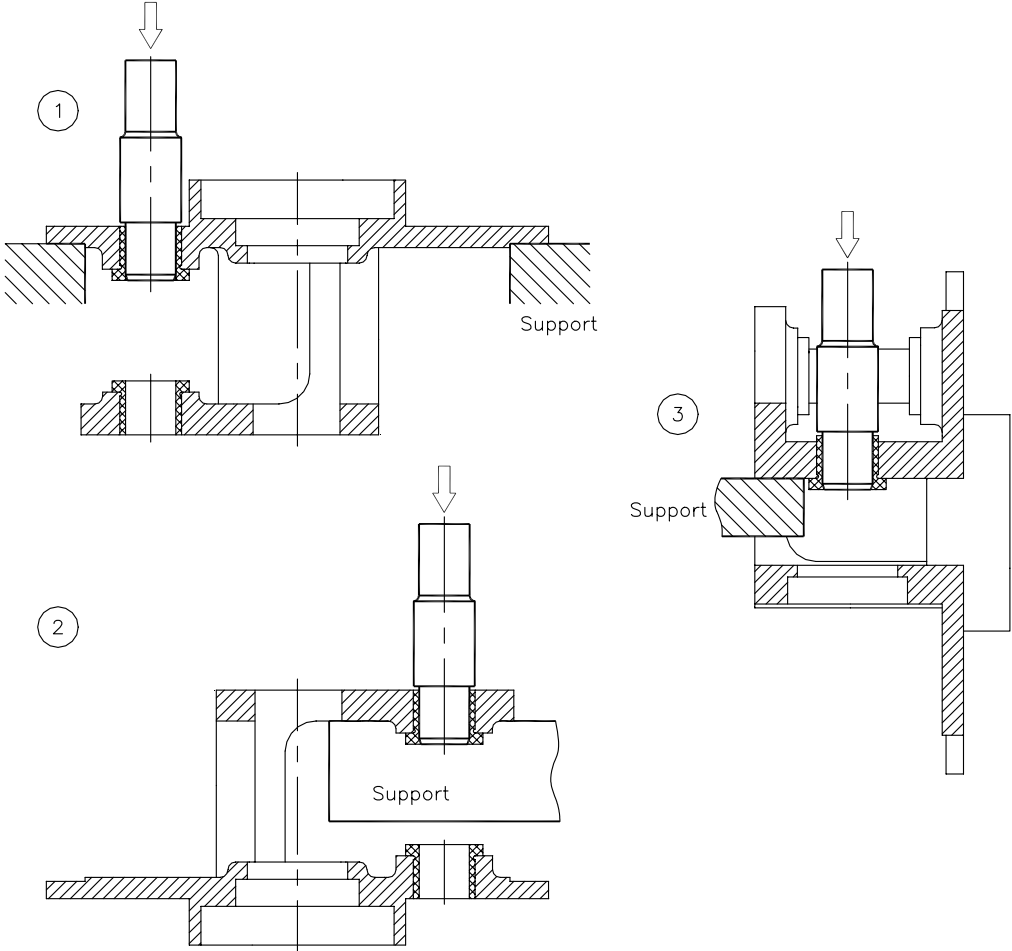

## Maintenance and Repair (continued)

### Replacement of Ball races

#### In Body

1. A. With big end downwards knock several times Body with bearings (pos. 26) hard against firm wooden support until Ball race (pos. 26.3) drops out.
1. B. If it is not possible to knock out Ball race in this way, it is necessary first to screw out Main collar lower (pos. 26.2) - see page 26. Carefully push off old Ball race without damaging Main collar lower. Use mandrel and firm support.

Before mounting of new Ball race, Main collar lower (pos. 26.2) must be remounted into Body - see page 26.

2. Clean surfaces and place Ball race (pos.26.3) on Main collar lower (pos. 26.2). Press by hand as long as possible. By means of a tube mandrel or if desired wooden block, carefully hammer Ball race home.

Ball race must not project over endface of Main collar lower. To avoid tilting mandrel must push along the whole circumference of Ball race. Do not damage surface of Ball race.

#### On Gear wheel

1. Place Gear wheel with ball race (pos. 7) on support. Support only under Ball race (pos. 7.1). With mandrel press off old Ball race.
2. Clean surfaces and press on new Ball race. Ball race must be pressed fully home on Gear. Press parallel. Use press or vice. Do not damage surface of Ball race.

#### In Hub cover

1. Place Hub cover with ball race (pos. 19) on support. Carefully knock out old Ball race by means of small mandrel or if desired screwdriver. Knock several times around the circumference to avoid tilting.
2. Clean surfaces and press in new Ball race. Ball race must be pressed fully home. Press parallel. Do not damage surface of Ball race.

# Maintenance and Repair (continued)

## Replacement of Ball races

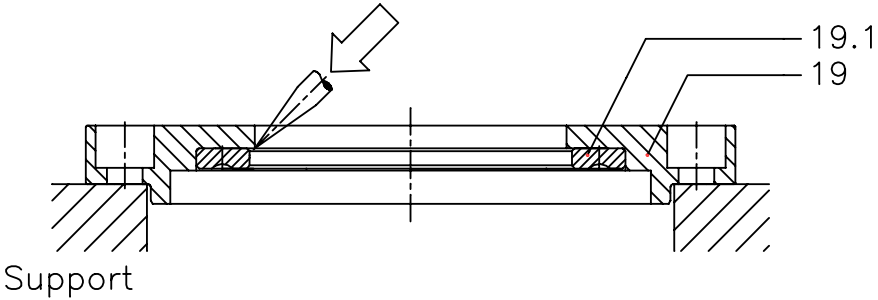
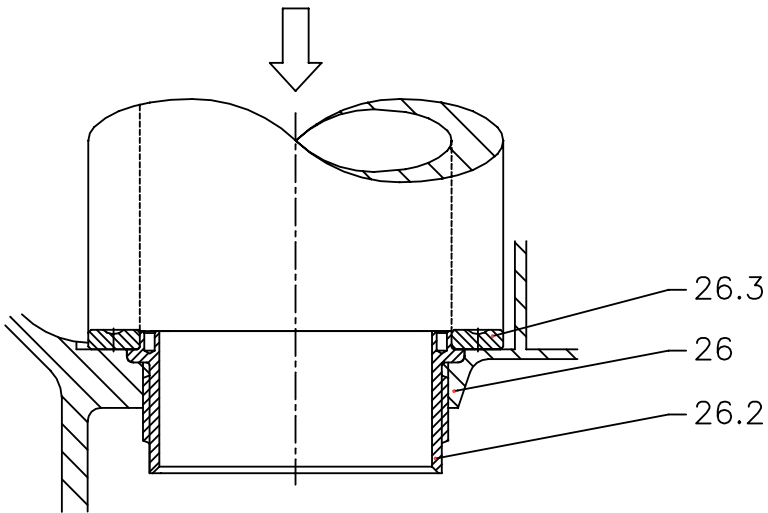
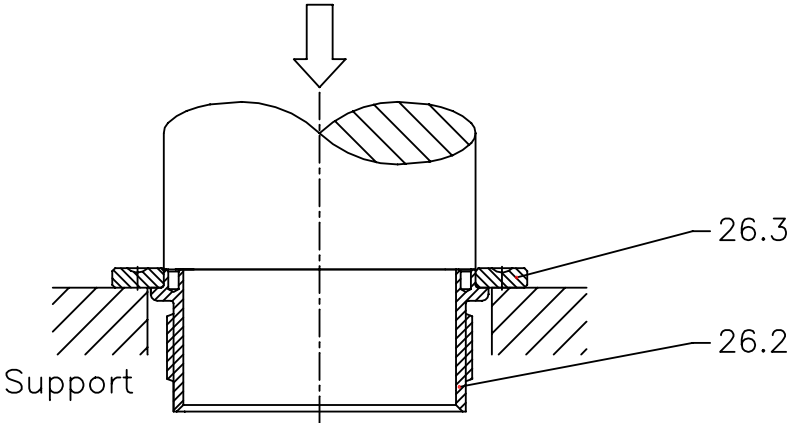

## Maintenance and Repair (continued)

### Replacement of Main Collars

Although normally exposed to very limited wear, it is possible to replace Main collars (pos. 26.1 and 26.2) in Body. The procedure to do this is described below.

#### Main collar upper

1. Place Body (pos. 26) in a vice in upright position. Do not clamp on machined faces. Insert Tool (see page 29) into Main collar upper (pos. 26.1). Unscrew Main collar.
2. Carefully clean thread and recess in Body. Do not damage special thread in Body. Recess must be absolutely clean.
3. Make sure that new Main collar is clean and free from impurities.
4. Screw in new Main collar. Attention should be given to make sure that thread is in correct engagement before screwing in Main collar.
5. Tighten Main collar fully home and tighten up.
6. Check that main collar is fully home: Install Stem, Ball retainer with balls and Gear wheel (see page 18). Check that there is sufficient axial clearance to allow for free rotation of Stem.

#### Main Collar Lower

Place Body in a vice in upside down position, and repeat procedure described above.

**Warning:** Thread on Main collar lower is left-handed.



# Maintenance and Repair (continued)

## Replacement of Main Collars

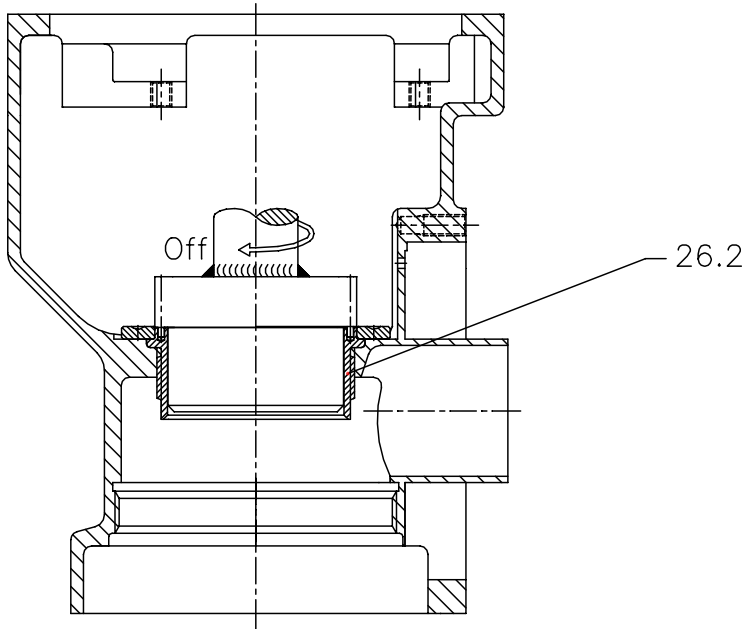
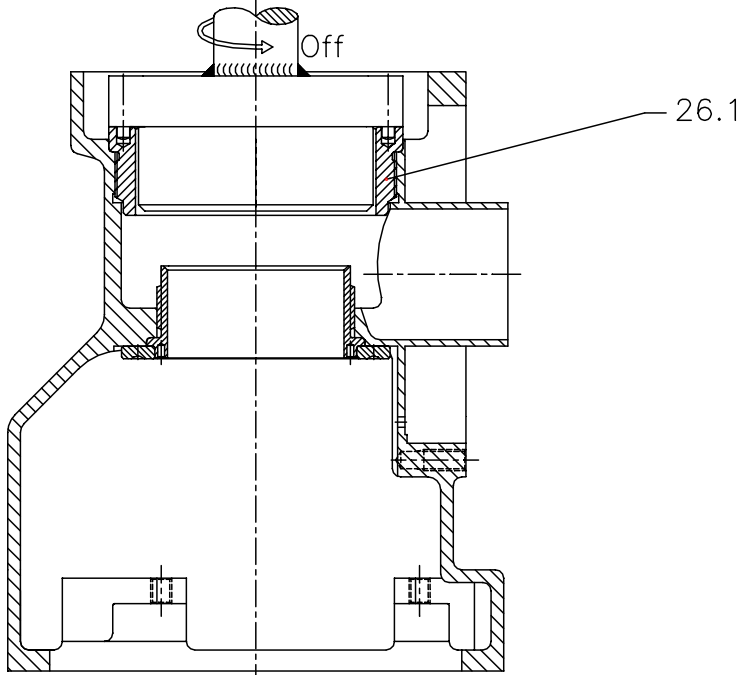

## Tools

### Standard Tool kit for Toftejorg TZ-67, Article no. TE81B050

Tool No.	Description	No.
TE134	Hex Key for Screw	1 pcs.
TE134A	Hex Screwdriver for Screw	2 pcs.

Available on request:

TE81B033 Pusher for Gear frame

### Sketch of Tools for replacement of Collar bush

TE81B033: Pusher for Gear frame

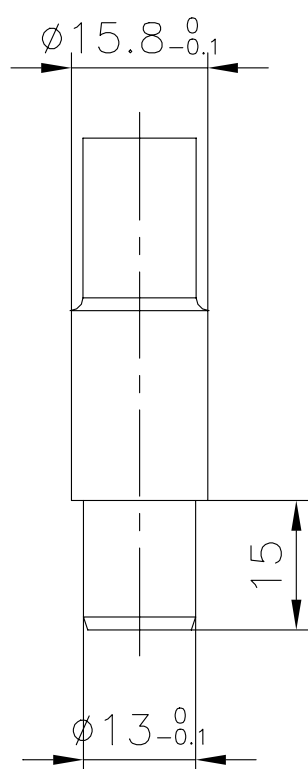

## Tools (continued)

### Sketch of tools for replacement of Main collars

TE81B129: Tool for Upper collar

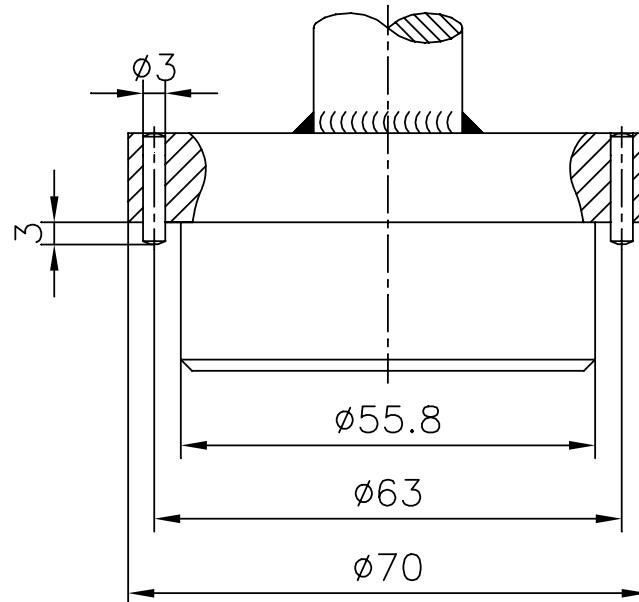

TE81B130: Tool for Lower collar

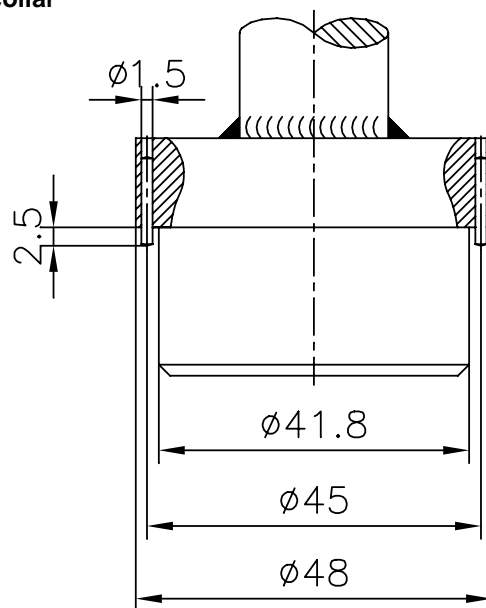

## Trouble Shooting Guide

### Symptom: Slow rotation or failure of the machine to rotate

Possible causes	Action
<b>No or insufficient liquid flow</b>	<p>a). Check if supply valve is fully open.</p> <p>b). Check if inlet pressure to machine is correct.</p> <p>c). Check supply line/filter for restrictions/clogging.</p> <p>d). Remove nozzles and check for clogging. If blocked, carefully clean nozzle without damaging stream straighteners and nozzle tip.</p> <p>e). Remove Flange/Nipple guide and Impeller (see page 12) and check for clogging in Impeller area.</p> <p>If large particles repeatedly get jammed in the machine, install filter or reduce mesh size of installed filter in supply line.</p>
<b>Foreign Material or Material Build-up</b>	<p>Insert hex Screwdriver in screw in top of Turbine shaft and easily turn Turbine shaft clockwise. If any resistance is recognized, disassemble machine to localize the cause:</p>
a). Impeller jammed	Remove Guide and Impeller (see page 12) and remove foreign material.
b). Turbine shaft sluggish in Main bush	Remove Turbine shaft (see page 14) and clean Main bush.
c). Bevel gears jammed	Remove Flange/Nipple and Hub Subassembly (see page 16). Clean teeth on Stem and Bevel gear.
d). Stem jammed/sluggish	Remove Gear subassembly (see page 14). Check free rotation of Stem. Remove Stem (see page 18). Remove foreign material/material build-up on Stem and inside Main Collars. Clean Ball Races and Ball retainer with balls. Also clean Main bush.

## Trouble Shooting Guide (continued)

Possible causes	Action
e). Gearbox jammed/sluggish	Remove foreign material from Gearbox. Check rotation of shafts. If restriction is recognized, disassemble Gear box (see page 20) and remove material build-up, especially on 2nd stage Worm wheel and mating Collar bushes.
f). Hub jammed/sluggish	Disassemble Hub Subassembly (see page 16). Remove foreign material inside Hub. Clean Ball races and Ball retainer with balls. Also clean nose of Body.

---

### Wear

a) Slide bearings	See page 10.
b) Main bush	See page 11.
c) Worm wheels	See page 11.
d) Collar bushes	See page 10.
e) Turbine shaft	Check clearance in Main bush and in Slide bearing. Transverse movement should not exceed 0,5 mm. Also inspect worm wheel for wear.
f) Horizontal shaft	Check clearance in Collar bushes. Transverse movement should not exceed 0,5 mm. Also inspect worm for wear.

---

### Mechanical defects

a) Worm wheel/Teeth broken	Replace Worm wheel.
b) Worm wheel can rotate on Horizontal shaft/Pinion due to damaged driver faces.	Replace Worm wheel.
c) Damaged teeth on Gear	Inspect teeth on Stem and Bevel gear for deformation. Mount Hub and Stem in Body (see page 16 and 18). Hold Body in upside down position and rotate Hub to check that Bevel gears can work together. If damaged: Replace Stem and/or Bevel gear.

## Reference List of Parts

### Toftejorg TZ-67, Parts List

Pos.	Ref. no.	No./unit	Description	Material	Remarks
1	<input type="checkbox"/> TE21B500	1	Nipple 1½" BSP	Stainless steel	Spare part
	<input type="checkbox"/> TE21B501	1	Nipple 1½" NPT	Stainless steel	Spare part
2	<input type="checkbox"/> TE703	1	Guide 100%	Stainless steel	Spare part
	<input type="checkbox"/> TE803-0	1	Guide ring 0%	Stainless steel	Spare part
3	TE21B526	1	Stem	Stainless steel	Spare part
4	TE705	1	Impeller 100%	Stainless steel	Spare part
5	TE21A525	1	Main bush	Polymer	Wear part
6	TE411K	1	Turbine shaft	Stainless steel	Wear part
7	TE712-13	1	Gear wheel w. ball race	Stainless steel	Spare part
7.1	TE826-1	1	Ball race	Stainless steel	Wear part
9	TE814	1	Pinion	Stainless steel	Spare part
10	TE21A585	3	Collar bush	Polymer	Wear part
11+33	TE21A367	1	Worm wheel w. reinforcem.	Polymer	Wear part
12	TE817	1	Journal	Stainless steel	Spare part
13	TE719A	4	Washer	Stainless steel	Spare part
14	TE731	2	Bearing cover	Stainless steel	Spare part
15	TE118	38	Screw	Stainless steel	Spare part
16	TE156	18	Spring washer	Stainless steel	Spare part
17	TE801A	1	Handle 1½" BSP	Bronze	Spare part
18	TE722S	1	Bevel gear w. ball race	Stainless steel	Spare part
18.1	TE826-1		Ball race	Stainless steel	Wear part
19	TE21B340	1	Hub cover w. ball race	Stainless steel	Spare part
19.1	TE826-1		Ball race	Stainless steel	Wear part
20	<input type="checkbox"/> TE50A006	4	Nozzle, ø6 mm	Stainless steel	Spare part
	<input type="checkbox"/> TE50A007	4	Nozzle, ø7 mm	Stainless steel	Spare part
	<input type="checkbox"/> TE50A008	4	Nozzle, ø8 mm	Stainless steel	Spare part
	<input type="checkbox"/> TE50A010	2	Nozzle, ø10 mm	Stainless steel	Spare part
20.1	TE50A000	2	Plug	Stainless steel	Spare part
21	TE21C536	1	Hub	Stainless steel	Spare part
22	TE21B549	1	Lip seal	Elastomer	Wear part
24	TE21A380	2	Ball retainer w. balls	Polymer/Stainless steel	Wear part
26	TE727Z4	1	Body	Stainless steel	Not available
26.1	TE21B520	1	Main collar upper	Polymer	Wear part
26.2	TE21B521	1	Main collar lower	Polymer	Wear part
26.3	TE826-1	1	Ball race	Stainless steel	Wear part
27	TE828Z	1	Horizontal shaft	Stainless steel	Wear part
28	TE21A570	2	Slide bearing	Polymer	Wear part
29	TE730	1	Gear frame	Stainless steel	Spare part
30	TE733-5	1	Bottom cover	Stainless steel	Spare part
33	TE21A367	1	Worm wheel w. reinforcem.	Polymer	Wear part

Please note that some of the polymer parts are in PEEK. PEEK is not resistant to concentrated sulfuric acid  
Configuration as delivered marked

# Cross Sectional Drawing

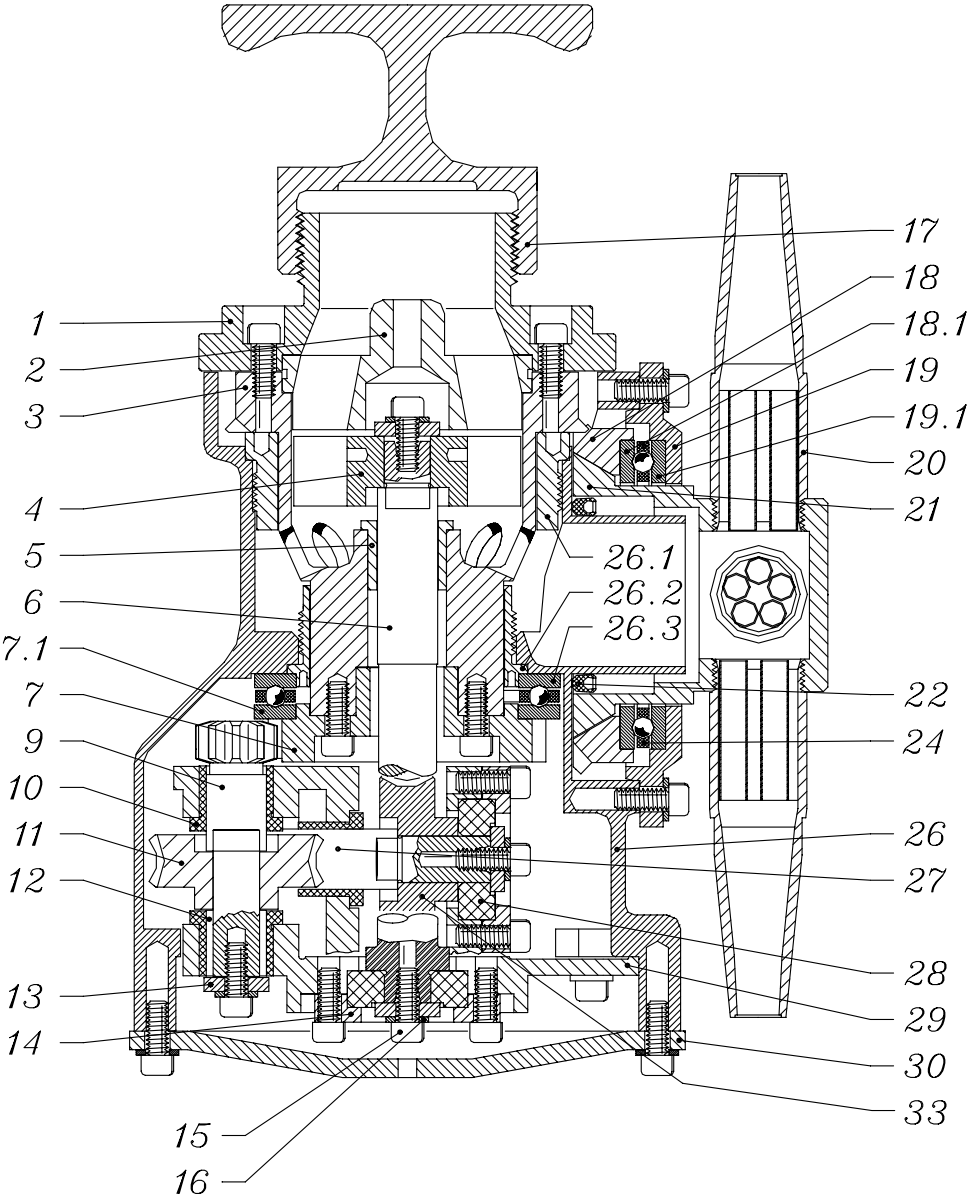

## Standard Service Kits and Upgrade Kits

### Standard Service Kit for Toftejorg TZ-67, Article No. TE55H000

For machines delivered after October 1, 1993

Part No.	Description	No.
TE21A367	Worm wheel w. reinforcement	2 pcs.
TE21A525	Main bush	1 pcs.
TE21A570	Slide bearing	2 pcs.
TE21A585	Collar bush	3 pcs.
TE651	Locking Wire	3 pcs.
TE21B549	Lip seal	1 pcs.

### Standard Service kit for Toftejorg TZ-67, Article No. TE21B299

For machines delivered before October 1, 1993

Part No.	Description	No.
TE21A367	Worm wheel w. reinforcement	2 pcs.
TE21A570	Slide bearing	2 pcs.
TE21A585	Collar bush	3 pcs.
TE21B375	Main bush	1 pcs.

### Upgrade Kit for Toftejorg TZ-67, Article No. TE21C285

Machines delivered January 1, 1986 – June 30, 1993

Part No.	Description	No.
TE21B328	Stem, complete	1 pcs.
TE21C536	4 Nozzle hub	1 pcs.
TE21B549	Lip seal	1 pcs.
TE21A525	Main bush	1 pcs.
TE21A570	Slide bearing	2 pcs.
TE21A367	Worm wheel	2 pcs.
TE411K	Turbine shaft	1 pcs.
TE826-1	Ball race	4 pcs.
TE21A380	Ball retainer w. balls	2 pcs.
TE21A585	Collar bush	3 pcs.
TE828Z	Horizontal shaft	1 pcs.

Upgrade kit including parts, new instruction manual, 1.5 working hours for upgrade and test. Machine subject to upgrade is to be sent to Alfa Laval workshop.

## Standard Service kits (continued)

### Upgrade Kit for Toftejorg TZ-67, Article No. TE21C286

#### Machines delivered after July 1, 1993

Part No.	Description	No.
TE21A525	Main bush	1 pcs.
TE21A570	Slide bearing	2 pcs.
TE21A367	Worm wheel	2 pcs.
TE411K	Turbine shaft	1 pcs.
TE826-1	Ball race	4 pcs.
TE21A380	Ball retainer w. balls	2 pcs.
TE21A585	Collar bush	3 pcs.
TE828Z	Horizontal shaft	1 pcs.
TE21B549	Lip seal	1 pcs.

Upgrade kit including parts, new instruction manual, 1.5 working hours for upgrade and test. Machine subject to upgrade is to be sent to Alfa Laval workshop.

## **How to order spare parts and claim procedure**

### **How to Order Spare Parts**

On the Cross Sectional Drawing as well as on all instruction drawings, the individual parts has a pos. number which is the same on all drawings. From the pos. number, the part is easily identified in the Reference list of Parts, page 32.

Individual parts should always be ordered from the Reference list of parts, page 32. Reference number and Description should be clearly stated.

Please also quote the type of machine and serial number. This will help us to help you. The type and serial number are stamped on the Body of the tank cleaning machine.

### **Claim Procedure**

In case of failure that needs assistance from Alfa Laval Tank Equipment A/S, it is essential for our evaluation that the problem as well as the working conditions of the machine are described as detailed as possible.

For description of the working conditions, fill in copy of Claim Report - Working Conditions, which you will find at the back of this manual.

## **How to contact Alfa Laval Tank Equipment A/S**

For further information please feel free to contact:

Alfa Laval Tank Equipment A/S  
Baldershoej 19  
P.O. Box 1149  
2635 Ishoej  
Denmark

Phone no.: +45 43 55 86 00  
Fax no.: +45 43 55 86 01  
[www.alfalaval.com](http://www.alfalaval.com)  
[www.toftejorg.com](http://www.toftejorg.com)

Contact details for all countries are continually updated on our websites.



# Claim Report Working Conditions

Page 1/2

**Ref. Claim Case** : \_\_\_\_\_

**Machine/Cleaner Type** : \_\_\_\_\_ **Serial No.:** \_\_\_\_\_

Configuration

- Nozzles : \_\_\_\_\_ x  $\varnothing$  \_\_\_\_\_ mm  
 - Turbine/Inlet Guide : \_\_\_\_\_ %

## Working Conditions

Inlet pressure at machine/cleaner : \_\_\_\_\_

Type of Valve in inlet line : \_\_\_\_\_

Can hydraulic shock be disregarded: :  Yes  No

Inlet line flushed before installation of tank cleaner? :  Yes  No

Working hours before failure : \_\_\_\_\_ hours

## Cleaning Programme

Cleaning media and conc.	Temperature	Time	Recirculation?

Is sterilising being used? :  Yes  No

Procedure (media/temp.)? : \_\_\_\_\_

Is steam injection being used for heating? :  Yes  No

Time: \_\_\_\_\_

Temperature: \_\_\_\_\_

v. 98.1

## Claim Report Working Conditions (continued)

Page 2/2

### Condition of Cleaning Media

- |   |   |
|---|---|
| <input type="checkbox"/> Clean                                      |   |
| <input type="checkbox"/> Contaminated with (nature and description) |   |
| <input type="checkbox"/> Chemicals/Solvents _____                   | <input type="checkbox"/> High viscous     |
| <input type="checkbox"/> Soluble                                    | <input type="checkbox"/> Sticky/tenacious |
| <input type="checkbox"/> Low viscous                                | <input type="checkbox"/> Solidifying      |
| <input type="checkbox"/> Hard particles/size _____                  | <input type="checkbox"/> Crystallizing    |
| <input type="checkbox"/> Soft particles/size _____                  |   |

Has filter been installed in inlet line?

- |                              |    |
|------------------------------|----|
| <input type="checkbox"/> Yes |    |
| Mesh size: _____             | mm |
| <input type="checkbox"/> No  |    |

Is tank cleaner flushed with clean water after tank cleaning?

- |                              |                             |
|------------------------------|-----------------------------|
| <input type="checkbox"/> Yes | <input type="checkbox"/> No |
|------------------------------|-----------------------------|

### Type of Soilage/Tank Contents to be removed

Name, formula/concentration of material to be removed from tank : \_\_\_\_\_

What is material soluble in : \_\_\_\_\_

Nature of material:

- |   |   |   |
|---|---|---|
| <input type="checkbox"/> Volatile/explosive | <input type="checkbox"/> Sticky/tenacious | <input type="checkbox"/> Contains soft particles        |
| <input type="checkbox"/> Low viscous        | <input type="checkbox"/> Solidifying      | <input type="checkbox"/> Contains hard particles/fibres |
| <input type="checkbox"/> High viscous       | <input type="checkbox"/> Crystallizing    |   |

Is tank cleaner submerged in material?

- |                              |                             |
|------------------------------|-----------------------------|
| <input type="checkbox"/> Yes | <input type="checkbox"/> No |
|------------------------------|-----------------------------|

### Other information/Remarks

---

---

Date: \_\_\_\_\_ Sign.: \_\_\_\_\_