



Instruction Manual

Toftejorg SaniJet 25

IM-TE91A760-EN2

Contents

- Contents 1
- Introduction 3
- General Description 4
 - Functioning 4
 - Configurations 5
 - Accessories 6
- Technical Data 8
- Installation and Normal Operation 10
 - General Installation Instructions 10
 - Normal Operation 11
- Trouble Shooting Guide 12
 - Symptom: Slow rotation or failure of machine to rotate 12
- How to contact Alfa Laval Tank Equipment A/S 12
- Cross Sectional Drawing 13
- Service Card 15
- Claim Report Working Conditions 16

Introduction

Based on more than 30 years of experience from practical tank cleaning and production, the Toftejorg SaniJet 25 has been developed to meet the highest demands for efficiency, reliability and hygiene within food and beverage, pharmaceutical and biochemical industry.

This manual has been prepared as a guide for the persons who will be only operating your tank cleaning machine.

If the Toftejorg SaniJet 25 stops rotating unintentionally, please return the machine to Alfa Laval Tank Equipment A/S.

The type and serial number are placed on the gear house of the tank cleaning machine.

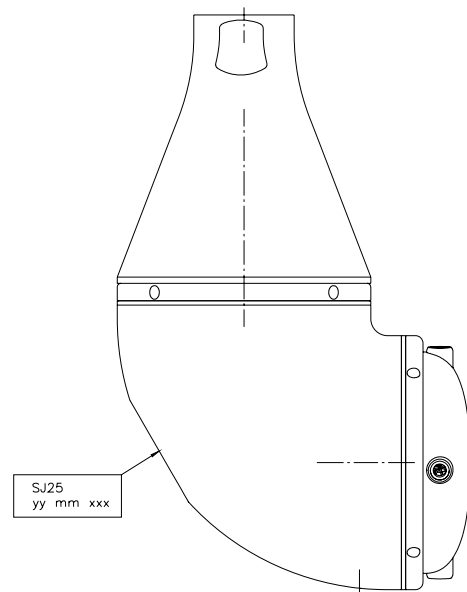

Note: The illustrations and specifications contained in this manual were effective at the date of printing. However, as continuous improvements are our policy, we reserve the right to alter or modify any unit specification on any product without prior notice or any obligation.

General Description

The Toftejorg SaniJet 25 is a media driven and media lubricated tank cleaning machine. No lubricating substances such as oil, grease etc. are used. All materials are selected for contact with food, and the machine is self-cleaning i.e. all internal and external surfaces are cleaned.

Functioning

The flow of the cleaning fluid into the machine passes through a turbine, which accordingly is set into rotation. Through a gear set and a driver tube, the turbine rotation is transmitted to the Cleaner Head.

The combined motion of the machine Body and the Nozzles ensures a fully indexed tank cleaning coverage. After $5\frac{5}{8}$ revolutions of the Hub cover with Nozzles ($5\frac{3}{8}$ revolutions of the machine Body), one coarse cleaning pattern is laid out on the tank surface and the first cycle has been made. During the following cycles, this pattern is repeated 7 times, each of which is displaced, and the pattern gradually becomes more dense. Finally, after 8 cycles - a total of 45 revolutions of the Hub Cover with Nozzles (43 revolutions of the machine Body), a complete cleaning pattern has been laid out, and the first pattern is repeated.

This is illustrated below for spherical tank with the machine placed in the centre:

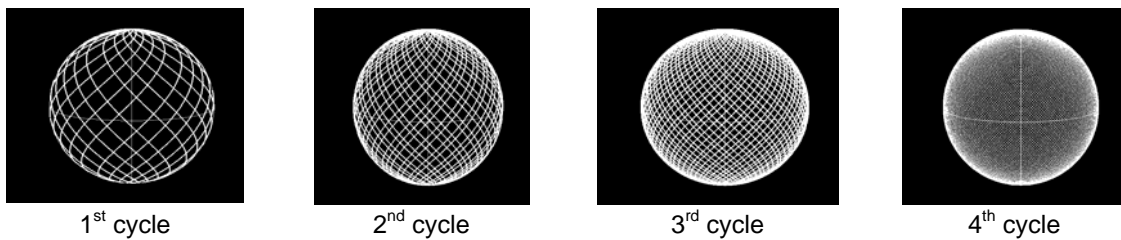

The number of cycles needed to perform a proper cleaning depends on type of soilage, distance, cleaning procedure and agent.

For substances that are easily mobilised, i.e. are easy to remove, one cycle could be sufficient while in cases of more heavy soilage (high viscous, sticky substances, etc.) a more dense pattern/more cycles will be needed.

The speed of rotation of the turbine depends on the flow rate through the machine. The higher the flow rate is, the higher the speed of rotation will be. In order to control the RPM of the machine for a wide range of flow rates, the machine has different turbines according to the Nozzle size.

General Description (continued)

Apart from the main flow flushing the gear and the Hub, and thereafter forming the jets through the Body nozzles and Hub nozzles, fluid is flushed through all internal areas, through bevel gear, Ball bearings and gaps between moving parts and is finally also used for cleaning of the outside surfaces of the machine. In the bottom of the Body, the machine is equipped with a hole to ensure self-draining. This self-draining is only ensured, if the machine is installed in upright position.

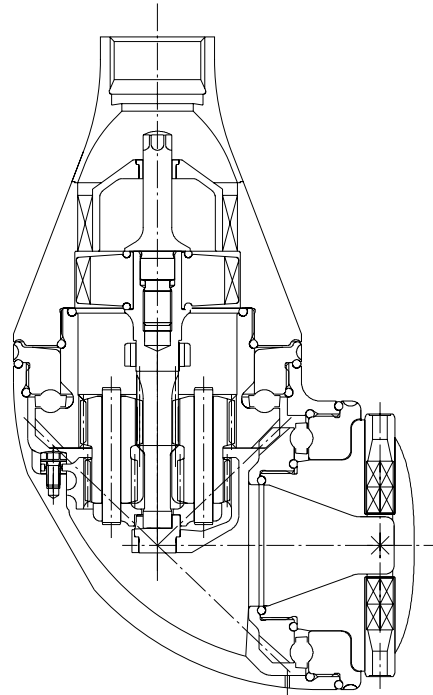

Configurations

Connection	Nozzles (mm)	Impeller
1" BSP, Female Sanitary	4 x \varnothing 4.2	35°
	4 x \varnothing 5.2	-2.5°
	4 x \varnothing 6.2	-22.5°

General Description (continued)

Accessories

Welding adapter with sealing assembly between Down pipe, Welding adapter and machine.

Pipe Dimension in mm		Connection thread	Article no.
1" ISO thread pipe:	ø33.7 x 3.25	1" BSP	TE52D030
1" ANSI Sch.40S:	ø33.4 x 3.38	1" NPT	TE52D031
1 ½" ISO Dairy pipe:	ø38 x 1.2	1" BSP	TE52D032
1 ½" SWG pipe:	ø38 x 1.6	1" NPT	TE52D033
1" ANSI Sch.40S:	ø33.4 x 3.38	1" BSP	TE52D034

Sanitary connection

Use Cone with Gasket.

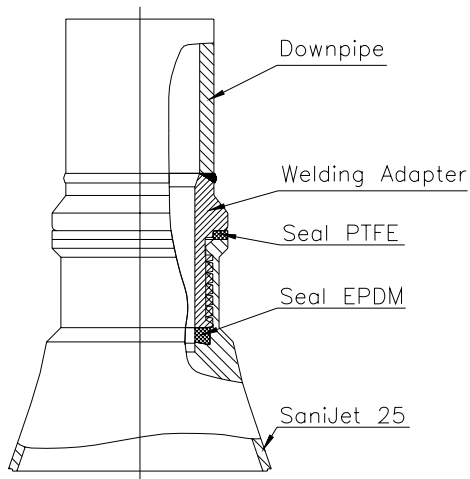

- Blank page -

Technical Data

Weight of machine	: 6,3 kgs (11,2 lb)
Working pressure	: 3-8 bar (40-115 psi)
Recommended inlet pressure	: 5-7 bar (70-100 psi)
Working temperature max.	: 95°C (200° F)
Max. temperature	: 140°C (284°F)
Materials	: Stainless steel AISI 316L, SAF 2205, Nitronic 60, PEEK, EPDM, PFA HP

Principal dimensions in mm

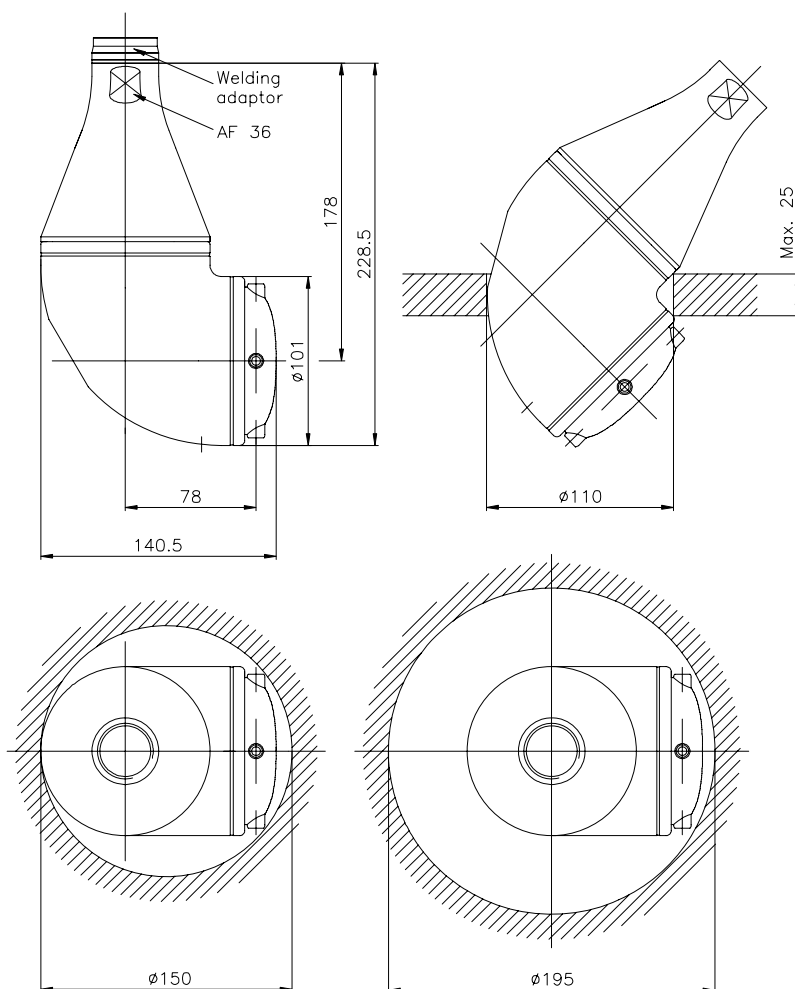

Technical Data (continued)

Performance Data

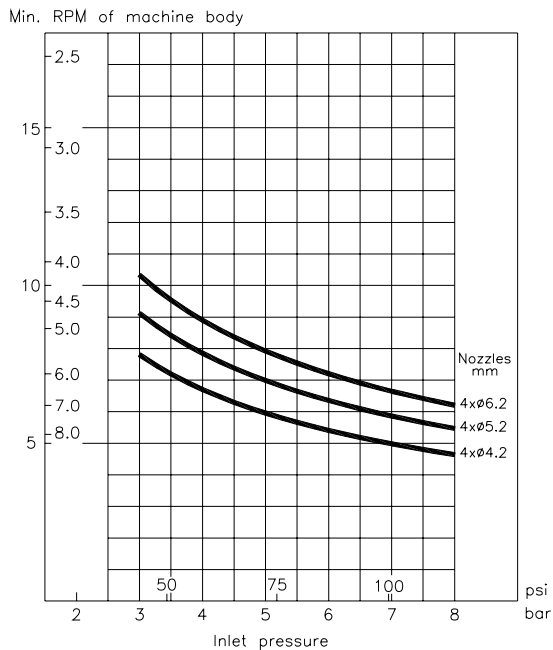
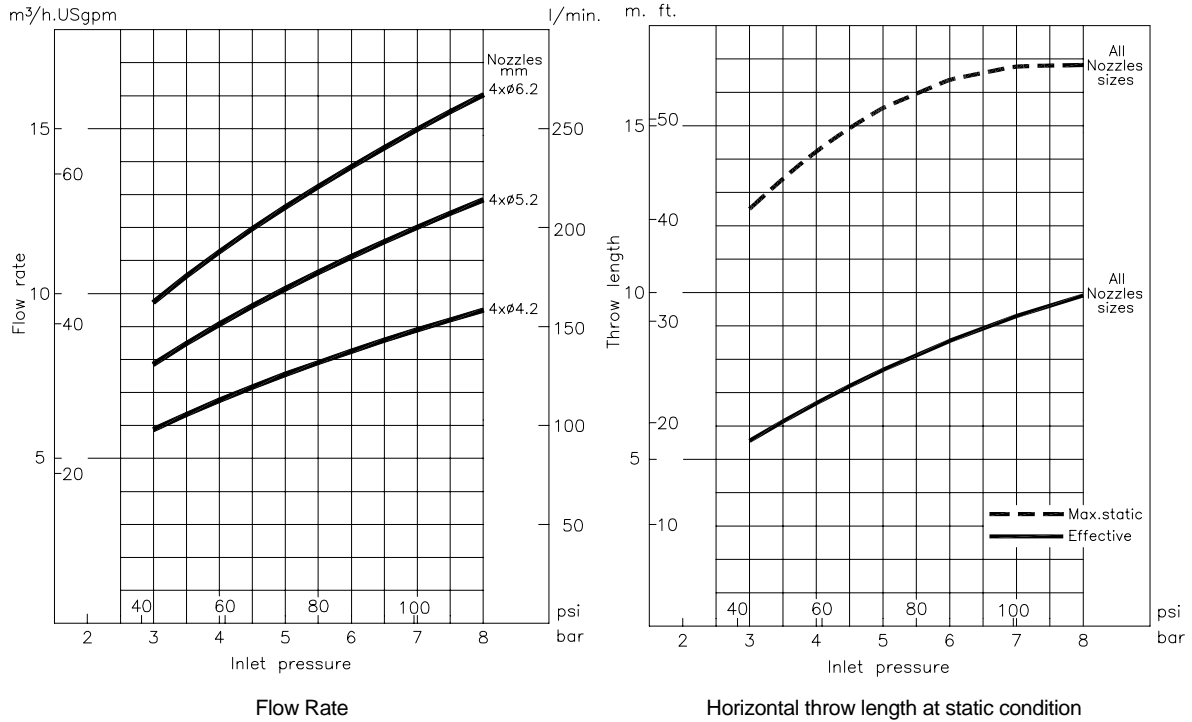

Cleaning time, complete pattern

Effective throw length is defined as impact in centre of jet 250 mm water column (50 lbs/sq.ft.). However, effective throw length varies depending on jet transverse speed over surface, substance to be removed, cleaning procedure and agent.

Note: Throw lengths are measured as horizontal throw length at static condition.

Vertical throw length upwards are approx. 1/3 less.

The inlet pressure has been measured immediately at the machine inlet. In order to achieve the performance indicated in the curves, pressure drop in the supply lines between pump and machine must be taken into consideration.

Installation and Normal Operation

General Installation Instructions

The Toftejorg SaniJet 25 tank cleaning machine should be installed in vertical position with the connections pointing up. It is recommended that the cleaning fluid supply line is equipped with a filter that will trap solids with a particle size of 50µm (0,002”) or larger. It is essential to avoid fine solid particles, as these particles will increase wear considerably and can become caught in one of the internal passages of the machine and cause it to stop rotating.

It is recommended that the fluid valve fitted is of a type that prevents hydraulic shocks, which may cause severe damage to the entire installation.

Before connecting the machine onto the system, all supply lines and valves should be flushed in order to remove foreign particles.

The machine should be screwed tightly onto its supporting supply line using a 36 mm flat jawed spanner (tool No. TE81B040) and the flats machined on the inlet Cone.

For devices with tapered thread connections to the down pipe, it is recommended that you secure the connection in a manner appropriate for the application. Subject to the intended use environment and any inhouse user requirements or policies, an adhesive such as Loctite No. 243 or equivalent could be used. Other methods could be acceptable and subject to customer preference.

Warning:



If the machine is used in potential explosive atmospheres, tapes or joint sealing compounds which are electrical insulators must not be used on threads or joints, unless an electrical connection is otherwise established to ensure an effective earthing. In addition, connecting pipe work, must be electrically conductive and earthed to the tank structure. The resistance between the nozzles and the tank structure should not exceed 20,000 Ohm. This is essential to avoid the build-up of static electricity on the machine. For further information see CENELEC R044-001 Safety of Machinery, guidance and recommendations for the avoidance of hazards due to static electricity.

Note: The machine shall be installed in accordance with national regulations for safety and other relevant regulations and standards.

Precautions shall be made to prevent starting of the cleaning operation, while personnel are inside the tank or otherwise can be hit by jets from the nozzles.

In EU-countries the complete system must fulfil the EU-machine directive and shall be CE-marked.

Installation and Normal Operation (continued)

Normal Operation

Cleaning Media

Use only media compatible with stainless steel AISI 316L, SAF 2205, Nitronic 60, PEEK, PFA HP and EPDM. Please note that PEEK is not resistant to concentrated sulphuric acid. Normal detergents, moderate solutions of acids and alkalis will be acceptable. Aggressive chemicals, excessive concentrations of chemicals at elevated temperatures, as well as certain hypochlorites should be avoided. If you are in doubt, contact your local Alfa Laval Tank Equipment sales office.

Pressure

Avoid hydraulic shocks. Increase pressure gradually. Do not exceed 8 bar inlet pressure. Recommended inlet pressure: 5-7 bar. High pressure in combination with high flow rate will increase consumption of wear parts. High pressure will also reduce the cleaning effect.

After Use Cleaning

After use flush the machine with fresh water. Cleaning media should never be allowed to dry or set-up in the system due to possible "salting out" or "scaling" of the cleaning media. If cleaning media contains volatile chloride solvents, it is recommended not to flush with water after use, as this might create hydrochloric acid.

Trouble Shooting Guide

Symptom: Slow rotation or failure of machine to rotate

Possible Causes	Fault finding
No or insufficient liquid flow	a). Check if supply valve is fully open. b). Check if inlet pressure to machine is correct. c). Check supply line/filter for restrictions/clogging.

How to contact Alfa Laval Tank Equipment A/S

For further information please feel free to contact:

Alfa Laval Tank Equipment A/S
Baldershoej 19
P.O. Box 1149
2635 Ishoej
Denmark

Phone no.: +45 43 55 86 00
Fax no.: +45 43 55 86 01
www.alfalaval.com
www.toftejorg.com

Contact details for all countries are continually updated on our websites.

Cross Sectional Drawing

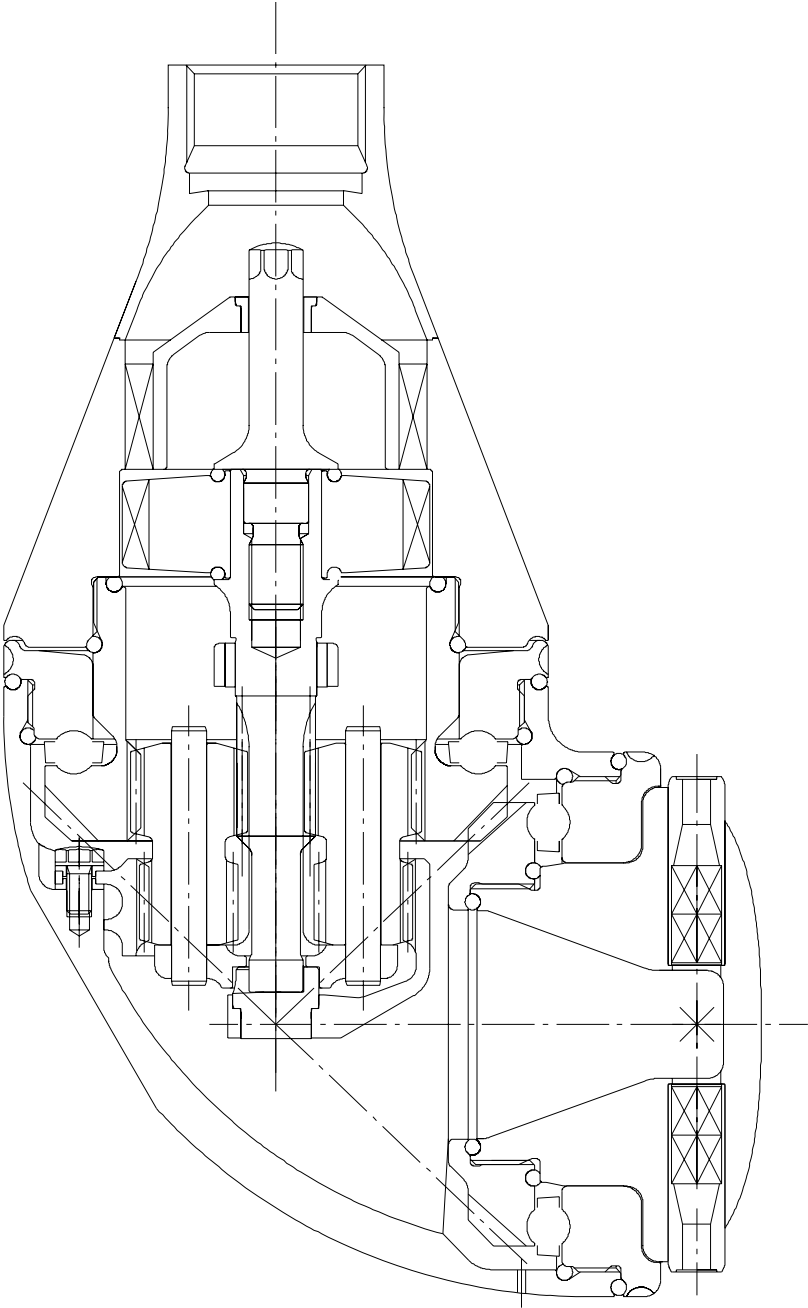

- Blank page -

Claim Report Working Conditions

Page 1/2

Ref. Claim Case : _____

Machine/Cleaner Type : _____ Serial No.: _____

Configuration

- Nozzles : _____ x \varnothing _____ mm
 - Turbine/Inlet Guide : _____ %

Working Conditions

Inlet pressure at machine/cleaner : _____

Type of Valve in inlet line : _____

Can hydraulic shock be disregarded: : Yes No

Inlet line flushed before installation of tank cleaner? : Yes No

Working hours before failure : _____ hours

Cleaning Programme

Cleaning media and conc.	Temperature	Time	Recirculation?

Is sterilising being used? : Yes No

Procedure (media/temp.)? : _____

Is steam injection being used for heating? : Yes No

Time: _____

Temperature: _____

v. 98.1

Claim Report Working Conditions (continued)

Page 2/2

Condition of Cleaning Media

- | | |
|---|---|
| <input type="checkbox"/> Clean | |
| <input type="checkbox"/> Contaminated with (nature and description) | |
| <input type="checkbox"/> Chemicals/Solvents _____ | <input type="checkbox"/> High viscous |
| <input type="checkbox"/> Soluble | <input type="checkbox"/> Sticky/tenacious |
| <input type="checkbox"/> Low viscous | <input type="checkbox"/> Solidifying |
| <input type="checkbox"/> Hard particles/size _____ | <input type="checkbox"/> Crystallizing |
| <input type="checkbox"/> Soft particles/size _____ | |

Has filter been installed in inlet line?

- | | |
|------------------------------|----|
| <input type="checkbox"/> Yes | |
| Mesh size: _____ | mm |
| <input type="checkbox"/> No | |

Is tank cleaner flushed with clean water after tank cleaning?

- | | |
|------------------------------|-----------------------------|
| <input type="checkbox"/> Yes | <input type="checkbox"/> No |
|------------------------------|-----------------------------|

Type of Sludge/Tank Contents to be removed

Name, formula/concentration of material to be removed from tank : _____

What is material soluble in : _____

Nature of material:

- | | | |
|---|---|--|
| <input type="checkbox"/> Volatile/explosive | <input type="checkbox"/> Sticky/tenacious | <input type="checkbox"/> Contains soft particles |
| <input type="checkbox"/> Low viscous | <input type="checkbox"/> Solidifying | <input type="checkbox"/> Contains hard particles |
| <input type="checkbox"/> High viscous | <input type="checkbox"/> Crystallizing | |

Is tank cleaner submerged in material?

- | | |
|------------------------------|-----------------------------|
| <input type="checkbox"/> Yes | <input type="checkbox"/> No |
|------------------------------|-----------------------------|

Other information/Remarks

Date: _____

Sign.: _____