



# Instruction Manual

Toftejorg MultiJet 25

IM-TE91A615-EN1

# Contents

Contents .....	1
Introduction .....	3
General Description .....	4
Functioning .....	4
Standard Configurations .....	5
Standard Options .....	5
Accessories .....	6
Technical Data .....	8
Performance Data .....	9
Installation and Normal Operation .....	10
General Installation Instructions .....	10
Normal Operation .....	11
Maintenance and Repair .....	12
Preventive Maintenance .....	12
Turbine and Carrier Assembly .....	14
Remaining Assemblies .....	16
Replacement of Ball Races .....	19
Standard Spare Part Kit, Service Kits and Tools .....	21
Standard Spare Part kit for Toftejorg MultiJet 25, Article No. TE20G299 .....	21
Service Kit for Toftejorg MultiJet 25 PTFE, Article No. TE20G285 .....	21
Service Kit for Toftejorg MultiJet 25, Article No. TE20G286 .....	21
Standard Tool Kit for Toftejorg MultiJet 25 .....	21
Trouble Shooting Guide .....	22
Symptom: Slow rotation or failure of machine to rotate .....	22
Exploded View Drawing .....	25
Reference List of Parts .....	26
Toftejorg MultiJet 25, Parts List .....	26
Cross Sectional Drawing .....	27
How to order Spare Parts and Claim Procedure .....	28
How to contact Alfa Laval Tank Equipment A/S .....	28
Service Card .....	29
Claim Report Working Conditions .....	30



## Introduction

With a new revolutionary patented design, the Toftejorg MultiJet 25 introduces a new generation of tank cleaning machines.

Based on more than 30 years experience from practical tank cleaning and production, the Toftejorg MultiJet 25 has been developed to meet the highest demands for efficiency, reliability and hygiene within food and beverage, pharmaceutical and biochemical industry.

This manual has been prepared as a guide for the persons who will be operating and maintaining your tank cleaning machine. The key to long life for your tank cleaning machine will always be a system of carefully planned maintenance; you will appreciate that a tank cleaning machine which has a rough and dirty job to do will need more frequent attention than one working in ideal conditions.

It is in your own interest to get the best and most economical performance from your tank cleaning machine. Neglect of maintenance means poor performance, unscheduled stoppages, shorter life and expense. Good maintenance means good performance; no unscheduled stoppages and better total economy.

You will find the information contained in this manual simple to follow, but should you require further assistance, our Customer Service Department and world-wide net of Distributors will be pleased to help you. Please quote the type and serial number with all your enquiries; this will help us to help you.

The type and serial number are placed on the gear house of the tank cleaning machine.

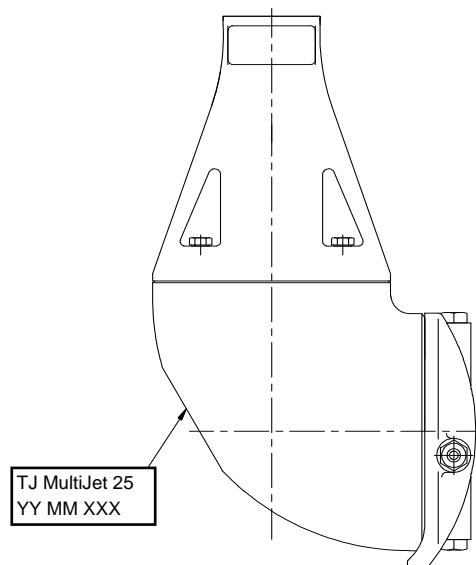

**Note:** The illustrations and specifications contained in this manual were effective at the date of printing. However, as continuous improvements are our policy, we reserve the right to alter or modify any unit specification on any product without prior notice or any obligation.

## General Description

The Toftejorg MultiJet 25 is a media driven and media lubricated tank cleaning machine. No lubricating substances such as oil, grease etc. are used. All materials are selected for contact with food, and the machine is self-cleaning i.e. all internal and external surfaces are cleaned.

## Functioning

The flow of the cleaning fluid into the machine passes through a turbine, which accordingly is set into rotation. Through a gear set and a driver tube, the turbine rotation is transmitted to the Cleaner Head.

The combined motion of the machine Body and the Nozzles ensures a fully indexed tank cleaning coverage. After  $5\frac{5}{8}$  revolutions of the Hub cover with Nozzles ( $5\frac{3}{8}$  revolutions of the machine Body), one coarse cleaning pattern is laid out on the tank surface and the first cycle has been made. During the following cycles, this pattern is repeated 7 times, each of which is displaced, and the pattern gradually becomes more dense. Finally, after 8 cycles - a total of 45 revolutions of the Hub Cover with Nozzles (43 revolutions of the machine Body), a complete cleaning pattern has been laid out, and the first pattern is repeated.

This is illustrated below for spherical tank with the machine placed in the centre:

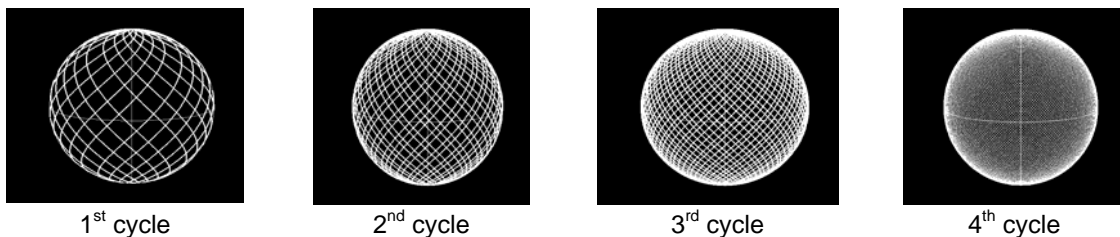

The number of cycles needed to perform a proper cleaning depends on type of soilage, distance, cleaning procedure and agent.

For substances that are easily mobilised, i.e. are easy to remove, one cycle could be sufficient while in cases of more heavy soilage (high viscous, sticky substances, etc.) a more dense pattern/more cycles will be needed.

The speed of rotation of the turbine depends on the flow rate through the machine. The higher the flow rate is, the higher the speed of rotation will be. In order to control the RPM of the machine for a wide range of flow rates, the machine has different turbines according to the Nozzle size.

## General Description (continued)

Apart from the main flow flushing the gear and the Hub, and thereafter forming the jets through the Nozzles, fluid is flushed through all internal areas, through bevel gear, Ball bearings and gabs between moving parts and is finally also used for cleaning of the outside surfaces of the machine. The areas behind the Screws on the Cone are cleaned through small spray holes behind the Screws. In the bottom of the Body, the machine is equipped with a hole to ensure self-draining. This self-draining is only ensured, if the machine is installed in upright position.

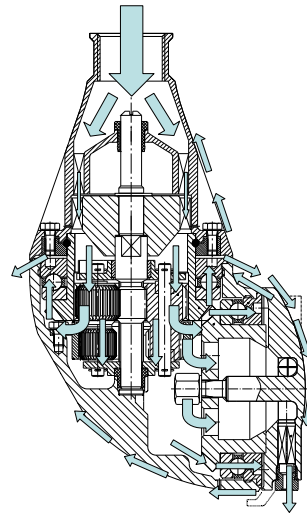

## Standard Configurations

Connection	Nozzles (mm)	Article No.
1" BSP, Female	4 x ø3,9	TE20G100
	4 x ø4,6	TE20G102
	4 x ø5,5	TE20G104
1" NPT, Female	4 x ø3,9	TE20G120
	4 x ø4,6	TE20G122
	4 x ø5,5	TE20G124

## Standard Options

Connection	Nozzles (mm)	PEEK Impeller	Article No.
1" BSP, Female	4 x ø3,9	TE20G595	TE20G100-02
	4 x ø4,6	TE20G596	TE20G102-02
	4 x ø5,5	TE20G597	TE20G104-02
1" NPT, Female	4 x ø3,9	TE20G595	TE20G120-02
	4 x ø4,6	TE20G596	TE20G122-02
	4 x ø5,5	TE20G597	TE20G124-02

## General Description (continued)

### Accessories

Welding adapter with sealing assembly between Down pipe, Welding adapter and machine.

Pipe Dimension in mm		Connection thread	Article no.
1" ISO thread pipe:	ø33.7 x 3.25	1" BSP	TE52D030
1" ANSI Sch.40S:	ø33.4 x 3.38	1" NPT	TE52D031
1 ½" ISO Dairy pipe:	ø38 x 1.2	1" BSP	TE52D032
1 ½" SWG pipe:	ø38 x 1.6	1" NPT	TE52D033
1" ANSI Sch.40S:	ø33.4 x 3.38	1" BSP	TE52D034

For devices with tapered thread connections to the down pipe, it is recommended that you secure the connection in a manner appropriate for the application. Subject to the intended use environment and any inhouse user requirements or policies, an adhesive such as Loctite No. 243 or equivalent could be used. Other methods could be acceptable and subject to customer preference.

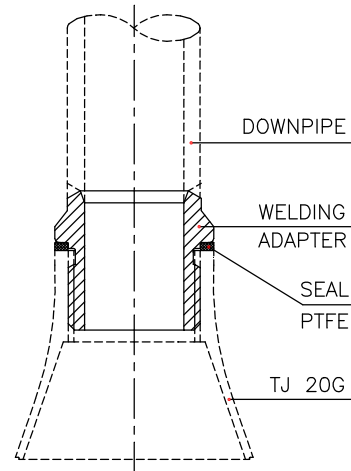

### Sanitary connection

Use Cone with Gasket.

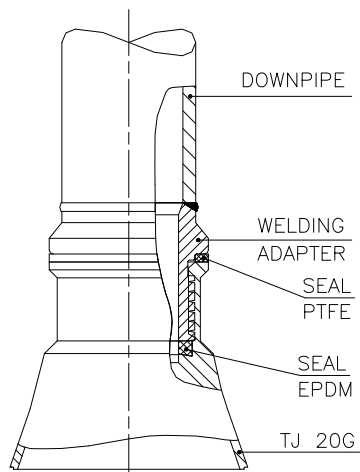

- Blank -

## Technical Data

Weight of machine	: 5,1 kgs (11 lb)
Working pressure	: 3-8 bar (45-115 psi)
Recommended inlet pressure	: 4-7 bar (58-100 psi)
Working temperature max.	: 95°C (200° F)
Max. temperature	: 140°C (284°F)
Materials	: Stainless Steel AISI 316L, Non-Galling Alloy, SAF 2205, PFA, PEEK, PVDF, A4/EPDM
Surface finish	: External surface finish: Mat

### Principal dimensions in mm

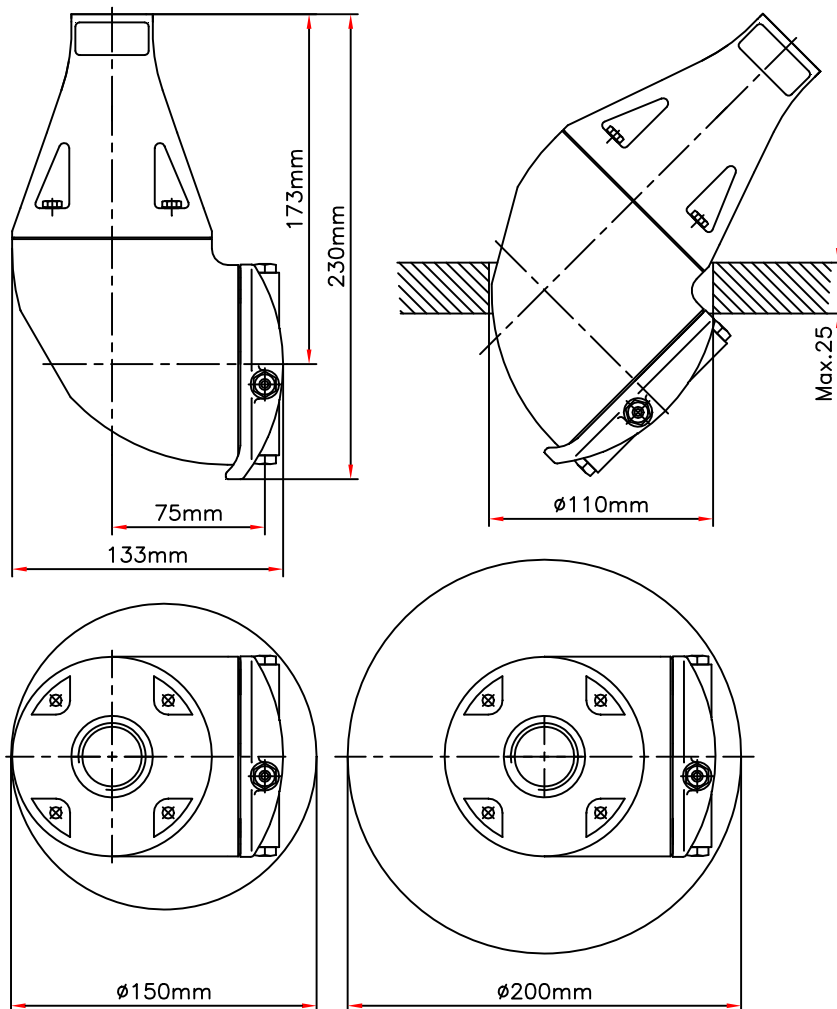

Minimum required passage:  $\varnothing 110$  mm (4.33 inch) at flange thickness 25 mm (0.98 inch)  
 Otherwise  $\varnothing 150$  mm (5.90 inch)

# Technical Data (continued)

## Performance Data

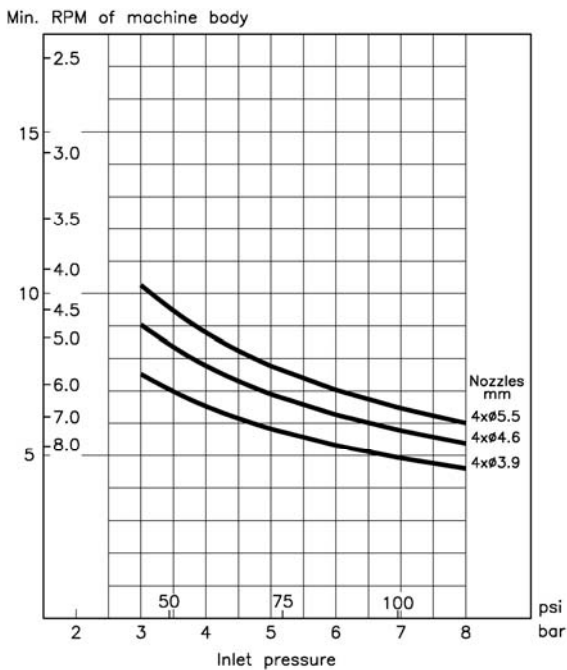
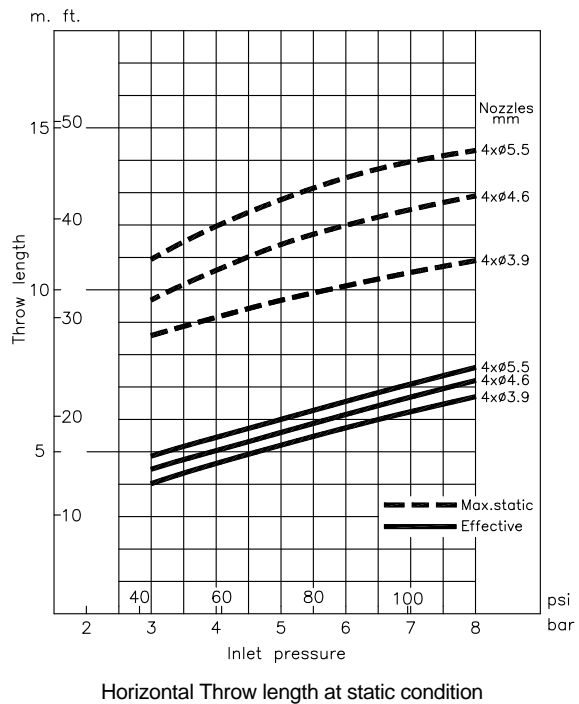
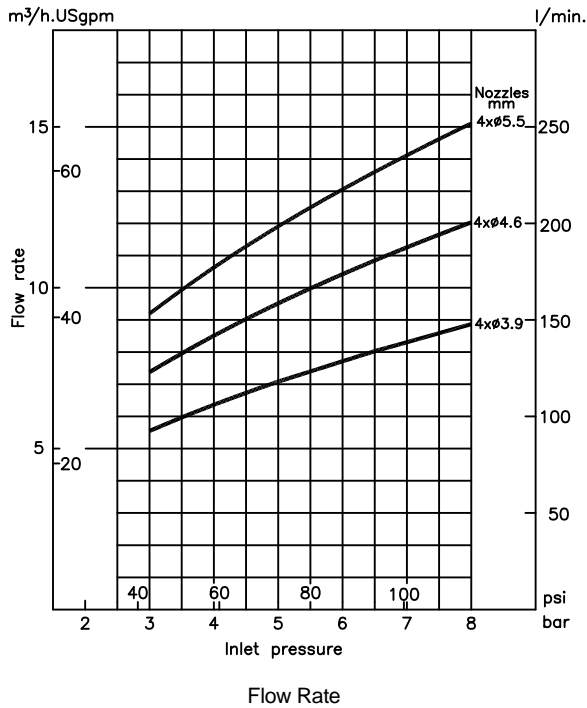

Cleaning time, complete pattern

Effective throw length is defined as impact in centre of jet 250 mm water column (50 lbs/sq.ft.). However, effective throw length varies depending on jet transverse speed over surface, substance to be removed, cleaning procedure and agent.

**Note:** Throw lengths are measured as horizontal throw length at static condition. Vertical throw length upwards are approx. 1/3 less.

The inlet pressure has been measured immediately at the machine inlet. In order to achieve the performance indicated in the curves, pressure drop in the supply lines between pump and machine must be taken into consideration.

# Installation and Normal Operation

## General Installation Instructions

The tank cleaning machine should be installed in vertical position (upright or upside down). It is recommended to install a filter in the supply line in order to avoid large particles, scale etc.- to clog inside the machine. It is essential to avoid fine solid particles, such as fine sand, in cleaning fluid as they will increase wear considerably.

In general a filter with 3 mm holes is recommended in the supply line. In case of fine solid particles below 500 µm in the cleaning fluid, choose filter size accordingly.

It is recommended that the fluid valve fitted is of a type that prevents hydraulic shocks, which may cause severe damage to the entire installation.

Before connecting the machine onto the system, all supply lines and valves should be flushed in order to remove foreign particles.

The machine should be screwed tightly onto its supporting supply line using a 36 mm flat jawed spanner (tool No. TE81B040) and the flats machined on the inlet Cone.

For devices with tapered thread connections to the down pipe, it is recommended that you secure the connection in a manner appropriate for the application. Subject to the intended use environment and any inhouse user requirements or policies, an adhesive such as Loctite No. 243 or equivalent could be used. Other methods could be acceptable and subject to customer preference.

**Warning:**



If the machine is used in potential explosive atmospheres, tapes or joint sealing compounds which are electrical insulators must not be used on threads or joints, unless an electrical connection is otherwise established to ensure an effective earthing. In addition, connecting pipe work, must be electrically conductive and earthed to the tank structure. The resistance between the nozzles and the tank structure should not exceed 20,000 Ohm. This is essential to avoid the build-up of static electricity on the machine. For further information see CENELEC R044-001 Safety of Machinery, guidance and recommendations for the avoidance of hazards due to static electricity.

**Note:** The machine shall be installed in accordance with national regulations for safety and other relevant regulations and standards.

Precautions shall be made to prevent starting of the cleaning operation, while personnel are inside the tank or otherwise can be hit by jets from the nozzles.

In EU-countries the complete system must fulfil the EU-machine directive and shall be CE-marked.

The machine has been tested at the factory before shipping. Check that the machine is in operating condition by inserting Screwdriver in top of Turbine shaft and easily turn Turbine shaft anti-clockwise. If any resistance is recognised, the machine should be disassembled in order to localise the cause.

## Installation and Normal Operation (continued)

### Normal Operation

#### Cleaning Media

Use only media compatible with Stainless Steel AISI 316L, Non-Galling Alloy, SAF 2205, PFA, PEEK, PVDF, A4/EPDM. Please note that PEEK is not resistant to concentrated sulphuric acid. Normal detergents, moderate solutions of acids and alkalis will be acceptable. Aggressive chemicals, excessive concentrations of chemicals at elevated temperatures, as well as certain hypochlorites should be avoided. If you are in doubt, contact your local Alfa Laval Tank Equipment sales office.

#### Pressure

Avoid hydraulic shocks. Increase pressure gradually. Do not exceed 8 bar inlet pressure. Recommended inlet pressure: 5-7 bar. High pressure in combination with high flow rate will increase consumption of wear parts. High pressure will also reduce the cleaning effect.

#### After Use Cleaning

After use flush the machine with fresh water. Cleaning media should never be allowed to dry or set-up in the system due to possible "salting out" or "scaling" of the cleaning media. If cleaning media contains volatile chloride solvents, it is recommended not to flush with water after use, as this might create hydrochloric acid.

## Maintenance and Repair

### Preventive Maintenance

In order to keep your tank cleaning machine servicing you as an efficient tool in your tank cleaning operations, it is essential to maintain its high performance by following a simple preventive maintenance programme, which will always keep your tank cleaning machine in good condition.

Good maintenance is careful and regular attention!

The following recommended preventive maintenance is based on tank cleaning machines working in average conditions. However, you will appreciate that a tank cleaning machine, which has a rough and dirty job to do, will need more frequent attention than one working in ideal conditions. We trust that you will adjust your maintenance programme to suit.

Always use only proper tools. Use Toftejorg MultiJet 25 standard tool kit. Never force, hammer or pry components together or apart. Always perform all assembly/disassembly steps in the order described in this manual.

Never assemble components without previous cleaning. This is especially important at all mating surfaces. Work in a clear well lighted work area.

#### Every 500 working hours

1. Disassemble machine as described on the following pages.
2. Clean material build-up and deposits from internal parts with Scotch-brite, S-Ultra-fine, eventually chemical media and fine abrasive cloth.
3. Check Slide bearing (Pos. 14, page 17 for wear. If end face of Slide bearing is worn more than 1 mm into Slide bearing, it should be replaced.
4. Check bearing for Turbine shaft top (Pos. 24, page 15) in Cone and Body. If holes are worn oval to a max. diameter of more than 10.4 mm, Bearings should be replaced. Thickness of collar is to be min. 3.5 mm for Bearing in Body. If the Bearings are loose in a horizontal direction, the bearings should be replaced.
5. Check Carrier bearing (Pos. 15.3, page 15). If worn oval to a max. diameter of more than 15.8 mm, it should be replaced.

**Note:** Timely replacement of Slide bearings and bearings for Turbine shaft will prevent costly damage to the gearbox.

## Maintenance and Repair (continued)

### Preventive Maintenance

6. Check Planet wheels (Pos. 15.4 and 15.5, page 15) while still mounted in planet gear carrier (Pos. 15.6, page 15). They must rotate easily on Shafts. If restriction or much clearance on Shafts is felt, Planet wheels should be dismantled for inspection of bearing bushes and Shafts for Planet wheel (Pos. 15.2, page 15). Max diameter of holes: 6.2 mm.

Check tooth wear.

If replacement is necessary, Planet wheels must be replaced as a pair.

7. Check unrestricted rotation of Ball bearings. Inspect for build-up of foreign material on Stem nut (Pos. 9) and Hub nut (Pos. 18), in Ball retainers (Pos. 10, page 17) and Ball races.
8. Assemble machines as described in the following pages.
9. Check that the machine is in operating condition by inserting Screwdriver in top of Turbine shaft, and easily turn Turbine shaft anti-clockwise. If any resistance is recognised, the machine should be disassembled in order to localise the cause.

Apart from the parts specifically mentioned above, all the remaining wear parts should regularly be inspected for wear. Wear parts are specified in the Reference List of Parts, page 26.

### Service Card

For your registration of maintenance carried out, fill in service card which you will find at the back of this manual.

## Maintenance and Repair (continued)

### Turbine and Carrier Assembly

#### Disassembly

1. Remove M5 Screws (Pos. 8). Loosen and unscrew with a socket wrench (tool No. TE462A).
2. Lift off Cone (Pos. 1).
3. Withdraw Turbine shaft (Pos. 2) with Impeller. If necessary, turn Turbine shaft left and right.
4. Remove Circlip (Pos. 4) and pull off Impeller (Pos. 5).
5. Withdraw Carrier assembly (Pos. 15) while turning/rocking carrier left and right.
6. Remove Cotter pins (Pos. 15.7), pull out Shafts (Pos. 15.2) and remove Planet wheels (Pos. 15.4 and 15.5). If necessary, push out Carrier bearing (Pos. 15.3)
7. If necessary, push out Bearing for Turbine shaft top (Pos. 24) from Cone (Pos.1).

#### Reassembly

Before reassembly, make sure that all parts are clean without deposits or build-up of foreign matter.

1. Insert Bearing for Turbine shaft top (Pos. 24) in top of Cone (Pos. 1).
2. Insert Carrier bearing (Pos. 15.3) and push with thumb. Insert Planet wheels (Pos. 15.4 and 15.5) and Shafts (Pos. 15.2) and secure with Cotter pins (Pos. 15.7). Check free rotation of Planet wheels.

**Note:** The two Planet wheels are different: on Planet wheel 1, teeth of upper and lower gearing are aligned, while they are displaced  $\frac{1}{2}$  tooth on Planet wheel 2.

3. Insert Carrier Assembly (Pos. 15), into Body: Insert through Stem (Pos. 16, page 17). Hold Body in one hand and use the other to turn Hub Cover (Pos. 19) left and right with small rocking movements until carrier falls through Internal gear (Pos. 13, page 17). Check that carrier is fully home on Bearing for Turbine shaft top (Pos. 24) in Body: Rotate Carrier Assembly by hand a few rotations to check correct position and function.
4. Mount Impeller (Pos. 5) on Turbine shaft (Pos. 2) and secure with Circlip (Pos. 4).
5. Insert Turbine shaft with Impeller through Carrier Assembly. Rotate Impeller to ensure correct insertion into Bearing for Turbine shaft (Pos. 3) in Body. Check unrestricted rotation.
6. Mount Cone (Pos. 1) over Turbine shaft and Retaining ring. Mount and tighten Screws (Pos. 8) with Socket wrench (tool No. TE462A).

# Maintenance and Repair (continued)

## Turbine and Carrier Assembly

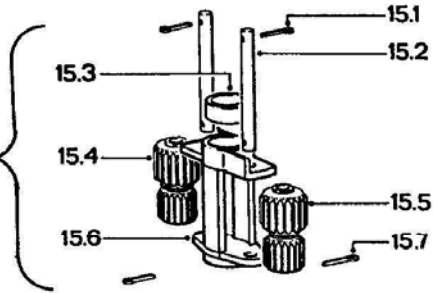
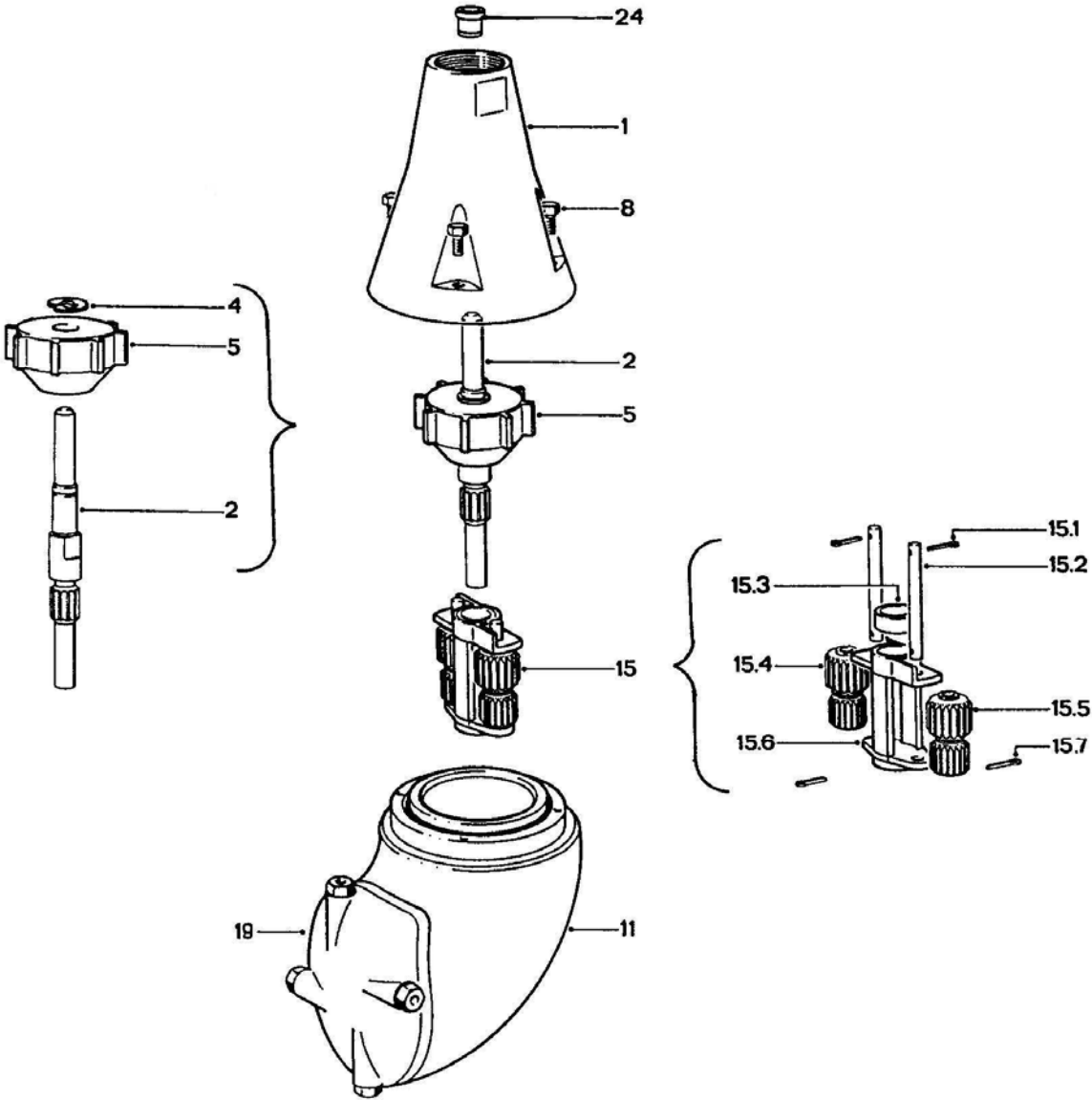

## Maintenance and Repair (continued)

### Remaining Assemblies

#### Disassembly

1. Remove Retainer spring (Pos. 6). Use small Screwdriver to lift Retainer spring out of groove in Stem (Pos. 16). Lift off Retaining ring (Pos. 7).
2. Hold Body against table and unscrew Stem nut w. ball race (Pos. 9) with Caliper (tool No. TE369). Withdraw Stem (Pos. 16) together with Ball retainer w. balls (Pos. 10).
3. Remove M5 Screws (Pos. 12) with a socket wrench (tool No. TE462A) and draw out Internal gear (Pos. 13).
4. Insert a 13 mm spanner (tool No. TE81B041) into Body, hold Cap nut (Pos. 23) and by hand screw off Hub cover (Pos. 19), and remove Washer (Pos. 22).
5. Hold Body against table and unscrew Hub nut w. ball race (Pos. 18) with Caliper (tool No. TE369).

**Note:** Left-hand thread

Withdraw Hub (Pos. 17) together with Ball retainer w. balls (Pos. 10).

6. With screwdriver lift Slide bearing (Pos. 14) and Bearing for Turbine shaft top (Pos. 24) out of Body.
7. Unscrew Nozzles (Pos. 21) with 11 mm spanner (tool No. TE81B041). Be careful not to damage Nozzle vanes (Pos. 20) as this will severely reduce Nozzle performance. Nozzle vanes should not be removed unless they need to be replaced.

If Ball races (Pos. 16.2 and 17.2) on Stem and Hub as well as Stem/Hub nut w. Ball race (Pos. 9 and 18) are heavily worn, they should be replaced as well as Ball retainer w. balls (Pos. 10), see page 19.

## Maintenance and Repair (continued)

### Remaining Assemblies

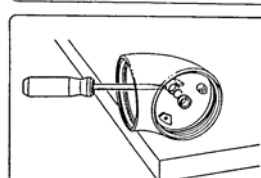
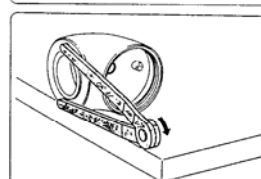
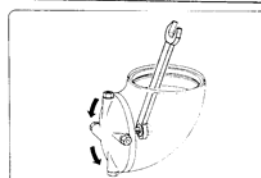
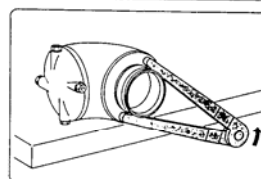
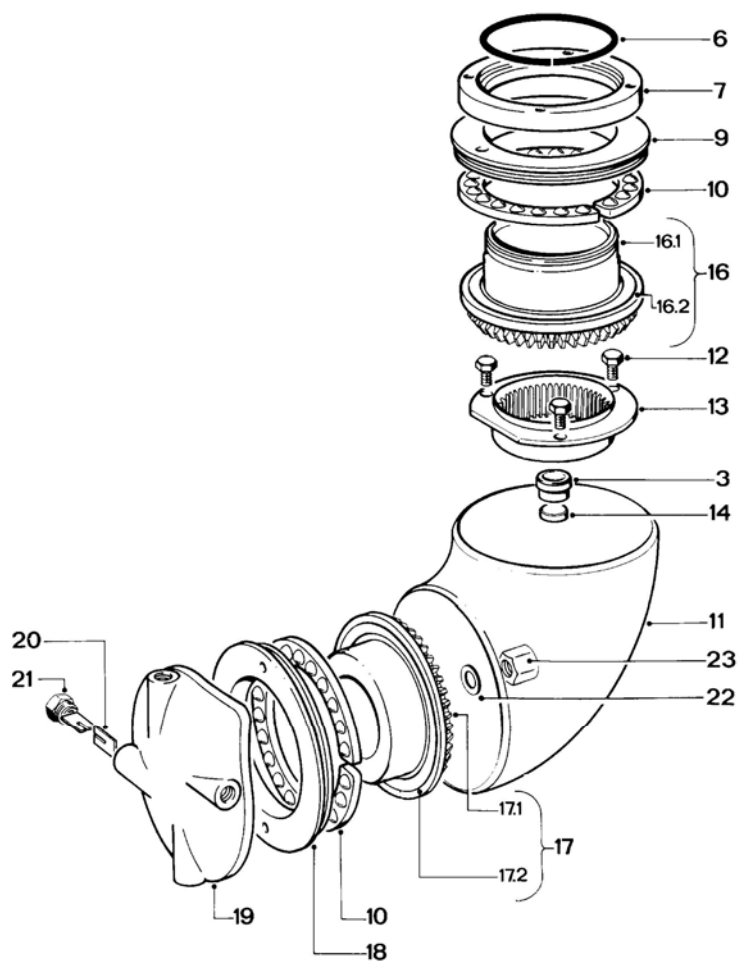

## Maintenance and Repair (continued)

### Remaining Assemblies

#### Reassembly

Before reassembly make sure that all parts are clean without deposits or build-up of foreign matter.

1. If necessary insert new Nozzle vanes (Pos. 20, see drawing page 17). Be careful not to damage Nozzle vanes. Mount Nozzles (Pos. 21) and tighten with spanner.
2. Place Slide bearing (Pos. 14) in Body and push in Bearing for Turbine shaft (Pos. 3) with thumb. Make sure that Bearing is fully home.
3. Inset Hub (Pos. 17) together with Ball retainer w. balls (Pos. 10). Mount Hub nut w. Ball race (Pos. 18) with Caliper (tool No. TE369) and tighten.

<b>Note:</b> Left-hand thread
-------------------------------

4. Place Washer (Pos. 22) on threaded pin on Hub cover and mount Cap nut (Pos. 23). Insert spanner (tool No. TE81B041) into Body, hold Cap Nut (Pos. 23) and by hand screw on Hub cover (Pos. 19) and tighten. Check free rotation of Hub.
5. Insert Internal gear (Pos. 13), mount Screws (Pos. 12) and tighten with Socket wrench (tool No. TE462A).
6. Insert Stem (Pos. 16) together with Ball retainer w. balls (Pos. 10). Mount Stem nut w. ball race (Pos. 9) with Caliper (tool No. TE369) and tighten. Turn Hub cover and check unrestricted rotation.
7. Place Retaining ring (Pos. 7) over Stem (Pos. 16) and push on Retainer spring (Pos. 6) and "click" into groove in Stem. Check free rotation.

## Maintenance and Repair (continued)

### Replacement of Ball Races

1. Place Stem or Hub complete (Pos. 16 or 17, see page 25) in a support ring and press off Ball race. Press parallel. Use press or vice. Be careful not to damage teeth and opposite end face of Stem.
2. With mandrel press Ball race fully home. Press parallel. Use press or vice. Be careful not to damage surface of Ball race.

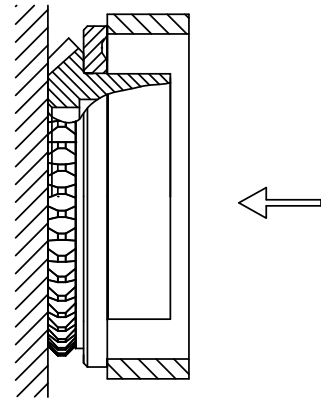
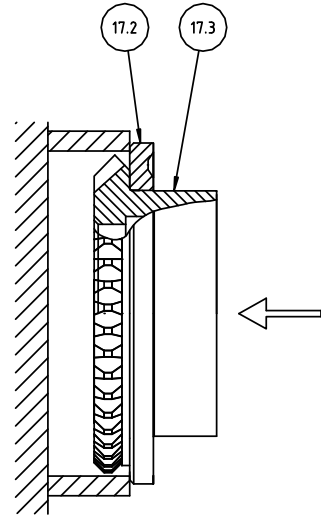

- Blank page -

## Standard Spare Part Kit, Service Kits and Tools

### Standard Spare Part kit for Toftejorg MultiJet 25, Article No. TE20G299

Part No.	Description	No.
TE20G535	Planet wheel I	1 piece
TE20G536	Planet wheel I	1 piece
TE20G545	Bearing for Planet Gear carr.	1 piece
TE20G549	Bearing for Turbine shaft	2 pieces
TE20G558	Slide bearing	1 piece

### Service Kit for Toftejorg MultiJet 25 PTFE, Article No. TE20G285

Part No.	Description	No.
TE20G549	Bearing for Turbine shaft	2 pieces
TE20G318	Ball retainer w. balls	2 pieces
TE20G558	Slide bearing	1 piece
TE20G535	Planet wheel I	1 piece
TE20G536	Planet wheel II	1 piece
TE51C102	Cotter pin	2 pieces
TE20G584	Washer,	1 piece
TE20G579	Liner	2 pieces
TE20G574	Ball race	2 pieces

### Service Kit for Toftejorg MultiJet 25, Article No. TE20G286

Part No.	Description	No.
TE20G549	Bearing for Turbine shaft	1 piece
TE20G318	Ball retainer w. balls	2 pieces
TE20G558	Slide bearing	1 piece
TE20G535	Planet wheel I	1 piece
TE20G536	Planet wheel II	1 piece
TE51C102	Cotter pin	2 pieces
TE20G584	Washer	1 piece
TE20G573	Hub nut with ball race	1 piece
TE20G571	Stem nut with ball race	1 piece
TE20G574	Ball race	2 pieces
TE20G548	Bearing for Turbine shaft top	1 pieces

### Standard Tool Kit for Toftejorg MultiJet 25

Tool No.	Description
TE369	Caliper
TE462A	socket wrench w. pin
TE81B040	Spanner for Toftejorg MultiJet 25
TE81B041	Spanner

## Trouble Shooting Guide

### Symptom: Slow rotation or failure of machine to rotate

Possible Causes	Fault finding
<b>No or insufficient liquid flow</b>	<p>a). Check if supply valve is fully open.</p> <p>b). Check if inlet pressure to machine is correct.</p> <p>c). Check supply line/filter for restrictions/clogging.</p> <p>d). Remove Nozzles and check for clogging. If blocked, carefully clean Nozzle without damaging Nozzles vanes and Nozzle tip.</p> <p>e). Remove Cone (see page 14) and check for clogging in Impeller of inlet guide inside Cone and in Impeller area.</p> <p>If large particles repeatedly get jammed in the machine, install filter or reduce mesh size of installed filter in supply line.</p>
<b>Foreign material or material build-up</b>	<p>Insert Screwdriver in Screw in top of Turbine shaft and easily turn Turbine shaft clockwise. If any resistance is recognised, disassemble machine in order to localise the cause.</p>
a). Impeller jammed	Remove Turbine shaft with Impeller and Carrier assembly (see page 14) and remove foreign material.
b). Turbine shaft sluggish in Bearings	Remove Turbine shaft with Impeller (see page 14) and clean Bearings.
c). Planet gear jammed/sluggish	Remove foreign material from Planet wheels and internal gears. Check rotation of Planet wheels. If restriction is recognised, disassemble Carrier assembly (see page 14) and remove material build up, especially on Shafts and bushes in Planet wheels.

## Trouble Shooting Guide (continued)

Possible Causes	Fault finding
d). Stem or Hub jammed/sluggish	Remove Carrier assembly (see page 14). Turn Hub cover and check unrestricted rotation. Remove Stem and Hub (see page 16-18). Remove foreign material/ material build-up on Stem, Hub and inside Nut w. ball race. Clean Ball races and Ball retainer with balls. Assemble Stem/Hub, Ball retainer with balls and Stem/Hub nut with ball race.
e). Bevel gears jammed	Remove Stem and Hub (see page 16). Clean teeth on Stem and Hub.
<b>Wear</b>	
a). Slide bearings	See page 12.
b). Bearing for Turbine shaft	See page 12.
c). Planet wheels	See page 13.
d). Shafts for Planet wheels	Check clearance of Planet wheels on Shafts. Transverse movement should not exceed 0.3 mm.
e). Turbine shaft	Check clearance in Carrier bearing and Bearing for Turbine shaft. Transverse movement should not exceed 0.3 mm. Also inspect teeth for wear.
<b>Mechanical defects</b>	
a). Planet wheels. Teeth broken	Replace Planet wheels.
b). Planet wheel can not rotate on Shafts/ Shafts bent.	Replace Shafts for Planet wheels.
c). Damaged teeth on Bevel gear	Inspect teeth on Stem and Hub for deformation. Mount Hub and Stem in Body (See page 18). Hold Body in upside down position and rotate Hub to check that bevel gears can work together. If damaged: Replace Stem and/or Hub.
d). Damage on Stem and Hub-nut	If hard particles get stuck between Stem nut and Stem or Hub nut and Hub, the particles will damage the parts. The damaged parts should be replaced.

- Blank -

# Exploded View Drawing

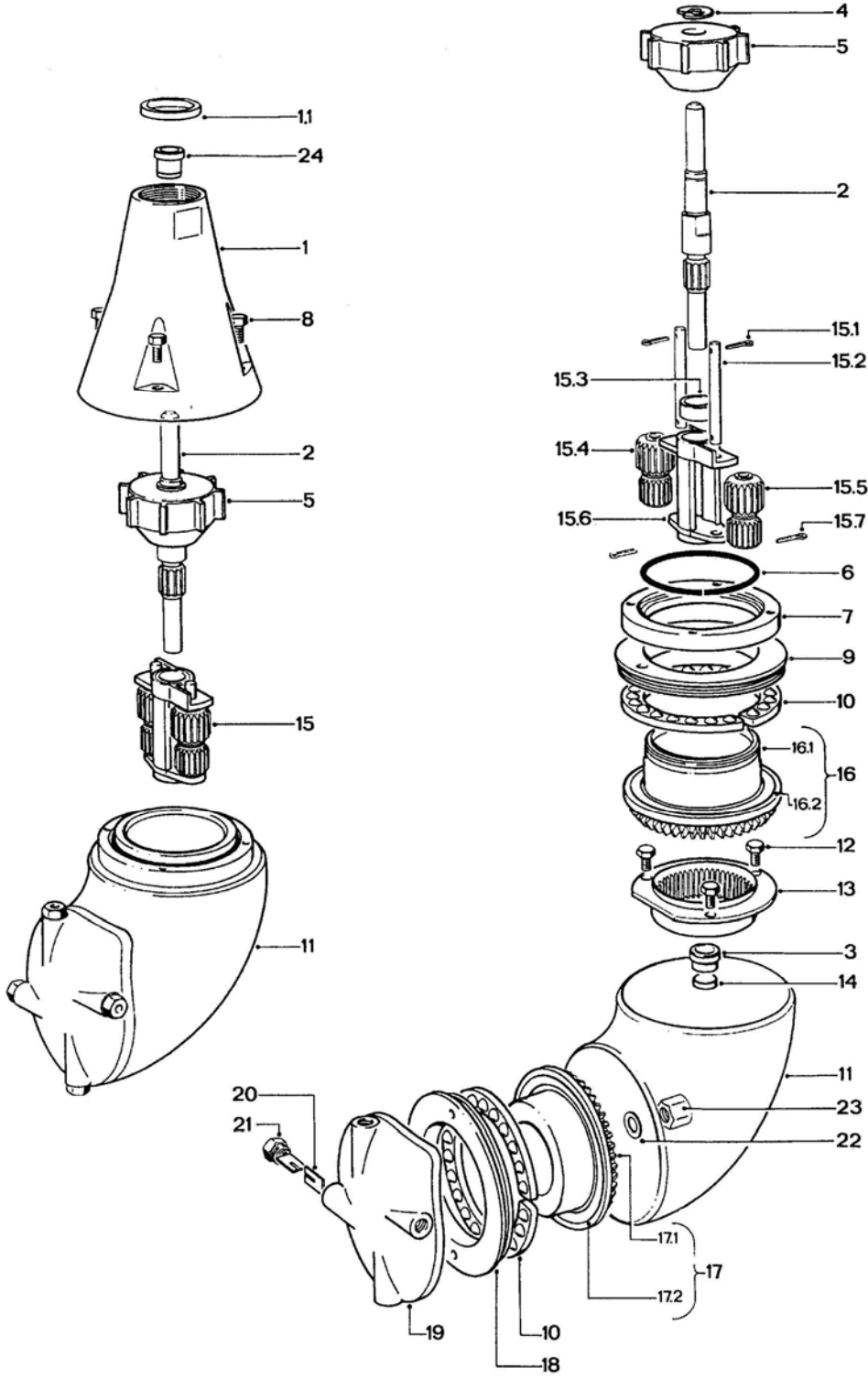

## Reference List of Parts

### Toftejorg MultiJet 25, Parts List

Pos.		Ref. No.	No/Unit	Description	Remarks
1	<input type="checkbox"/>	TE20G506	1	Cone 1" BSP	Spare part
	<input type="checkbox"/>	TE20G507	1	Cone 1" NPT	Spare part
2		TE20G550	1	Turbine shaft	Spare part
3		TE20G549	1	Bearing for Turbine shaft	Wear part
4		TE51C201	1	Circlip	Spare part
5	<input type="checkbox"/>	TE20G553	1	Impeller (ø3.5/3.9 mm nozzle)	Spare part
	<input type="checkbox"/>	TE20G554	1	Impeller (ø4.5/4.6 mm nozzle)	Spare part
	<input type="checkbox"/>	TE20G555	1	Impeller (ø5,5 mm nozzle)	Spare part
	<input type="checkbox"/>	TE20G595	1	Impeller (ø3.5/3.9 mm nozzle)	Spare part
	<input type="checkbox"/>	TE20G596	1	Impeller (ø4.5/4.6 mm nozzle)	Spare part
	<input type="checkbox"/>	TE20G597	1	Impeller (ø5.5 mm nozzle)	Spare part
6		TE20G565	1	Retainer spring	Spare part
7		TE20G563	1	Retaining ring	Spare part
8		TE51A172	4	Screw	Spare part
9		TE20G571	1	Stem nut with ball race	Wear part
10		TE20G318	2	Ball retainer with balls	Wear part
11		TE20G511	1	Body	Spare part
12		TE51A170	3	Screw	Spare part
13		TE20G525	1	Internal gear	Spare part
14		TE20G558	1	Slide bearing	Wear part
15		TE20G330	1	Carrier assembly	Spare part
15.1		TE51C102	2	Cotter pin	Spare part
15.2		TE20G541	2	Shaft for Planet wheel	Spare part
15.3		TE20G545	1	Carrier bearing	Wear part
15.4		TE20G535	1	Planet wheel I	Wear part
15.5		TE20G536	1	Planet wheel II	Wear part
15.6		TE20G530	1	Planet gear carrier	Spare part
15.7		TE51C102	2	Cotter pin (= pos. 15.1)	Spare part
16		TE20G319	1	Stem complete	Spare part
16.1		TE20G624	(1)	Stem	Spare part
16.2		TE20G574	(1)	Ball race	Wear part
17		TE20G320	1	Hub complete	Spare part
17.1		TE20G625	(1)	Hub	Spare part
17.2		TE20G574	(1)	Ball race (= pos. 16.2)	Wear part
18		TE20G573	1	Hub nut with ball race	Wear part
19		TE20G619	1	Hub cover with pin	Spare part
20		TE20G594	8	Nozzle vane	Spare part
21	<input type="checkbox"/>	TE20G608	4	Nozzle ø3,9 mm	Spare part
	<input type="checkbox"/>	TE20G609	4	Nozzle ø4,6 mm	Spare part
	<input type="checkbox"/>	TE20G605	4	Nozzle ø5,5 mm	Spare part
22		TE20G584	1	Washer	Spare part
23		TE51A521	1	Cap nut	Spare part
24		TE20G548	1	Bearing for turbine shaft top	Wear part

Configuration as delivered marked

# Cross Sectional Drawing

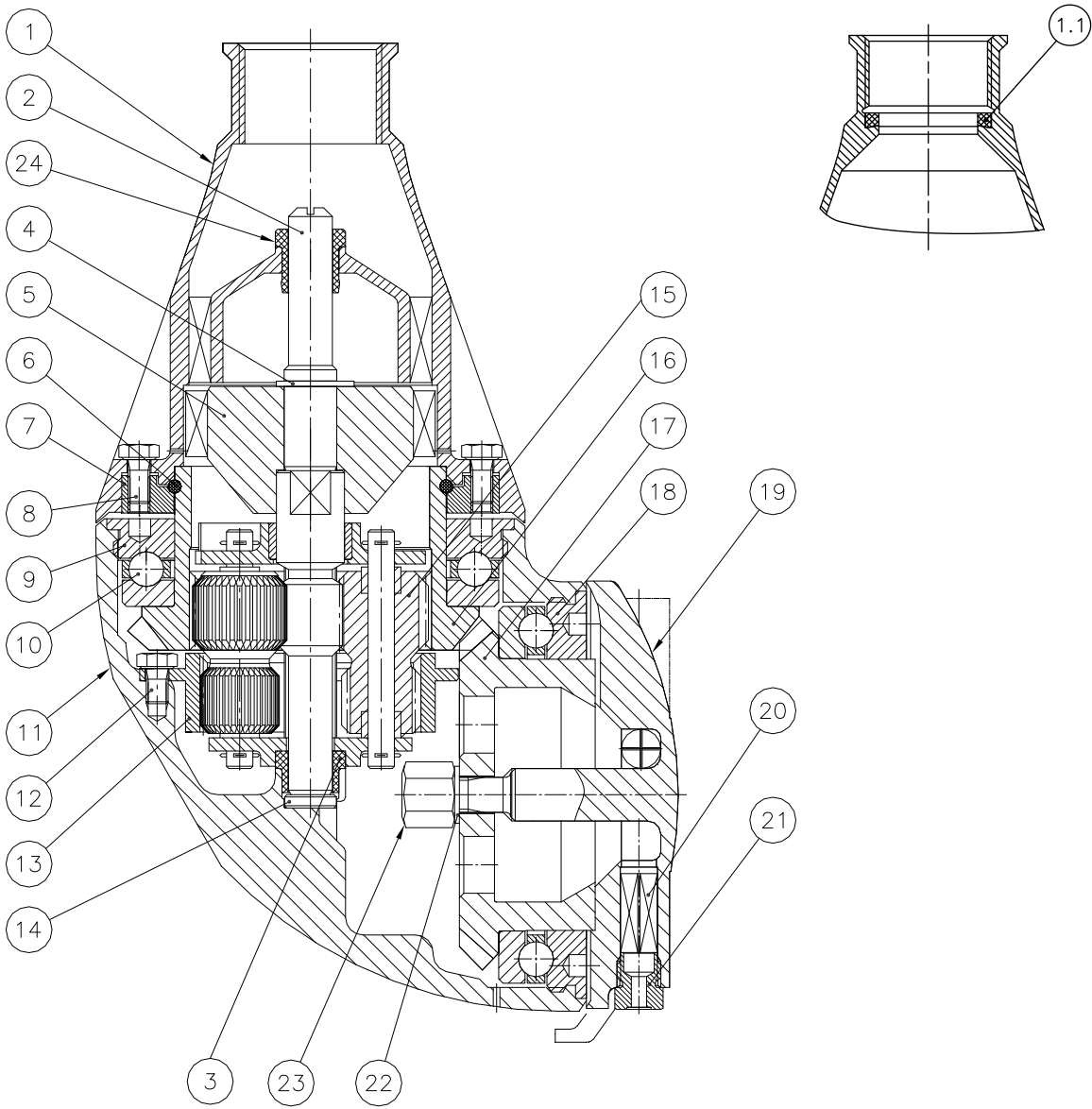

## How to order Spare Parts and Claim Procedure

### How to Order Spare Parts

On the Cross Sectional Drawing as well as on all instruction drawings, the individual parts have a pos. no., which is the same on all drawings in the Operators Manual. From the pos. no. the part is easily identified in the Reference List of Parts, page 26.

Individual parts should always be ordered from the Reference List of Parts, page 26. Ref. No. and Description should be clearly stated.

Please also quote the type of machine and serial No. This will help us to help you. The type and serial Nos. are stamped on the Body of the tank cleaning machine.

### Claim Procedure

In case of failure that needs assistance from Alfa Laval Tank Equipment A/S, it is essential for our evaluation that the problem as well as the working conditions of the machine are described as detailed as possible.

For description of the working conditions, fill in copy of Claim Report - Working Conditions, which you will find at the back of this manual.

## How to contact Alfa Laval Tank Equipment A/S

For further information please feel free to contact:

Alfa Laval Tank Equipment A/S  
Baldershoej 19  
P.O. Box 1149  
2635 Ishoej  
Denmark

Phone no.: +45 43 55 86 00  
Fax no.: +45 43 55 86 01  
[www.alfalaval.com](http://www.alfalaval.com)  
[www.toftejorg.com](http://www.toftejorg.com)

Contact details for all countries are continually updated on our websites.



# Claim Report Working Conditions

Page 1/2

Ref. Claim Case : \_\_\_\_\_

Machine/Cleaner Type : \_\_\_\_\_ Serial No.: \_\_\_\_\_

Configuration

- Nozzles : \_\_\_\_\_ x  $\varnothing$  \_\_\_\_\_ mm  
 - Turbine/Inlet Guide : \_\_\_\_\_ %

## Working Conditions

Inlet pressure at machine/cleaner : \_\_\_\_\_

Type of Valve in inlet line : \_\_\_\_\_

Can hydraulic shock be disregarded: :  Yes  No

Inlet line flushed before installation of tank cleaner? :  Yes  No

Working hours before failure : \_\_\_\_\_ hours

## Cleaning Programme

Cleaning media and conc.	Temperature	Time	Recirculation?

Is sterilising being used? :  Yes  No

Procedure (media/temp.)? : \_\_\_\_\_

Is steam injection being used for heating? :  Yes  No

Time: \_\_\_\_\_

Temperature: \_\_\_\_\_

v. 98.1

## Claim Report Working Conditions (continued)

Page 2/2

### Condition of Cleaning Media

- |   |   |
|---|---|
| <input type="checkbox"/> Clean                                      |   |
| <input type="checkbox"/> Contaminated with (nature and description) |   |
| <input type="checkbox"/> Chemicals/Solvents _____                   | <input type="checkbox"/> High viscous     |
| <input type="checkbox"/> Soluble                                    | <input type="checkbox"/> Sticky/tenacious |
| <input type="checkbox"/> Low viscous                                | <input type="checkbox"/> Solidifying      |
| <input type="checkbox"/> Hard particles/size _____                  | <input type="checkbox"/> Crystallizing    |
| <input type="checkbox"/> Soft particles/size _____                  |   |

Has filter been installed in inlet line?

- |                              |    |
|------------------------------|----|
| <input type="checkbox"/> Yes |    |
| Mesh size: _____             | mm |
| <input type="checkbox"/> No  |    |

Is tank cleaner flushed with clean water after tank cleaning?

- |                              |                             |
|------------------------------|-----------------------------|
| <input type="checkbox"/> Yes | <input type="checkbox"/> No |
|------------------------------|-----------------------------|

### Type of Sludge/Tank Contents to be removed

Name, formula/concentration of material to be removed from tank : \_\_\_\_\_

What is material soluble in : \_\_\_\_\_

Nature of material:

- |   |   |  |
|---|---|--|
| <input type="checkbox"/> Volatile/explosive | <input type="checkbox"/> Sticky/tenacious | <input type="checkbox"/> Contains soft particles |
| <input type="checkbox"/> Low viscous        | <input type="checkbox"/> Solidifying      | <input type="checkbox"/> Contains hard particles |
| <input type="checkbox"/> High viscous       | <input type="checkbox"/> Crystallizing    |  |

Is tank cleaner submerged in material?

- |                              |                             |
|------------------------------|-----------------------------|
| <input type="checkbox"/> Yes | <input type="checkbox"/> No |
|------------------------------|-----------------------------|

### Other information/Remarks

---

---

Date: \_\_\_\_\_

Sign.: \_\_\_\_\_