



# Fast, Sanitary Cleaning

## Toftejorg SaniMega Rotary Spray Head

ESE00333EN 0901

### Application

The Toftejorg SaniMega rotary spray head provides a controlled rotating fan impact cleaning action. It is an automatic device with an optimised design for effective distribution of cleaning media. The Toftejorg SaniMega is suitable in processing and storage tanks ranging from 50 to 350 m<sup>3</sup> (13,000 to 92,000 US gallons). It is particularly suited to vertical storage tanks in the food, brewing and other beverage industries where a scrubbing effect is needed to clean at the fill level.

### Working principle

The flow of the cleaning media causes the gear unit to rotate the body of the cleaning head. The resulting fan impact jet provides a swirling action down the tank wall.

### Spray Pattern

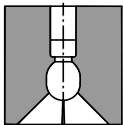

270° up

### Standard Design

Downpipe length 1,200 mm (47.2 inch). Inlet connection as welding end 2" ISO (Ø51 x 1.2mm / Ø2 x 0.05 inch). Tank inlet as DIN Union DN100. As standard documentation, the Toftejorg SaniMega can be supplied with a "Declaration of Conformity" for material specifications.

### Materials

1.4404 (316L), PEEK, EPDM

### Technical Data

|                                 |  |
|---------------------------------|--|
| Weight:                         | 6 kg (13 lbs)  |
| Lubricant:                      | Self-lubricating with the cleaning fluid   |
| Working pressure:               | 2 - 4 bar (29 - 58 psi)  |
| Recommended pressure:           | 3 bar (44 psi)   |
| Max. working temperature:       | 95 °C (203 °F)   |
| Max. sterilisation temperature: | 140 °C (284 °F)  |
| Max. ambient temperature:       | 140 °C (284 °F)  |
| Effective cleaning radius:      | 3 m (10 ft)  |
| Standard connection:            | Inlet: 2" ISO clamp<br>Tank: 3" ISO clamp  |
| Standard downpipe length:       | 1,200 mm (47.2 inch)   |
| Min. tank opening:              | Ø72.5 mm (Ø2.9 inch)   |
| Standard Surface finish:        | Product contact parts<br>Ra0.8µm (32µ inch) -<br>Non product contact parts<br>Ra1.6µm (64µ inch) |



### Certificate:

2.1

### Ordering

Please specify desired spray pattern, required connections, material selection and type of certification required. Please also confirm the application suitability.

Sizing/selection and installation drawings are available in Alfa Laval's Selection Tools for Tank Cleaning Equipment.

### Options

- A. Rotation sensor
- B. Counter parts to the standard clamp connections, including gaskets and clamp rings

**Dimensions (mm / inch)**

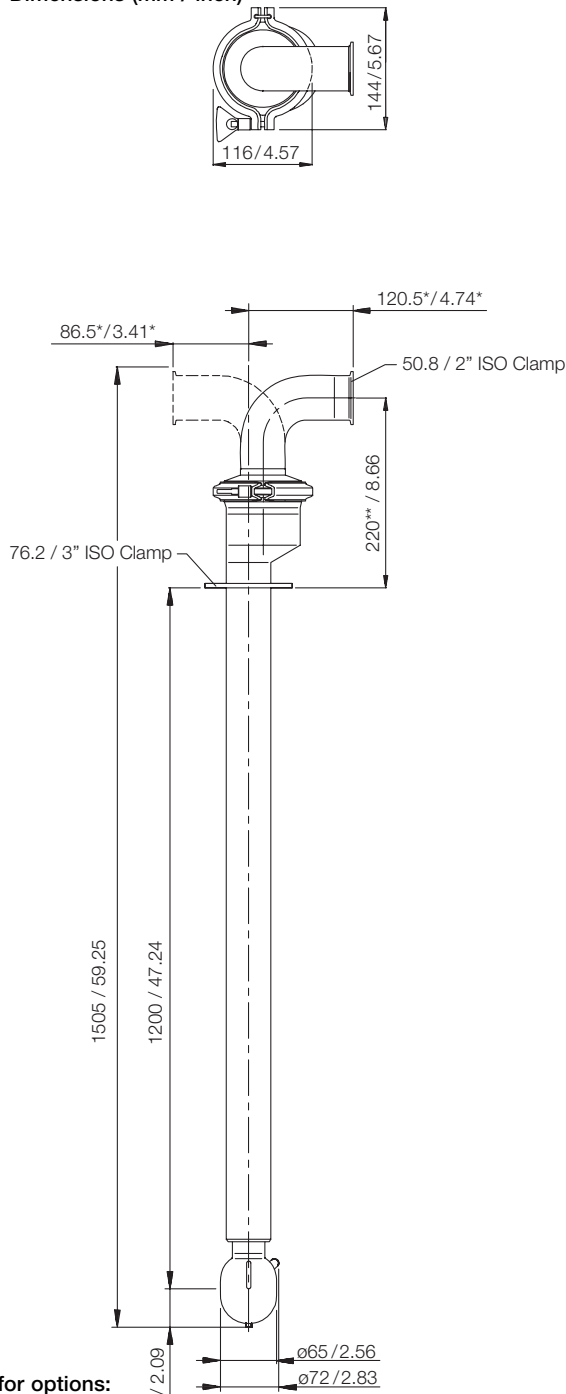

**Dimensions for options:**

\* For welding end: 65/99 mm (2.6/3.9 inch)

\*\* For DIN DN100: 234 mm (9.2 inch)

**Flow Rate**

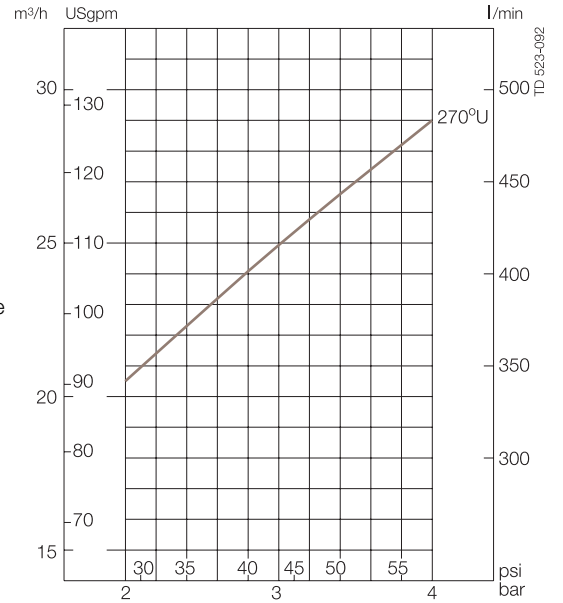

**Inlet pressure  
Rotating speed**

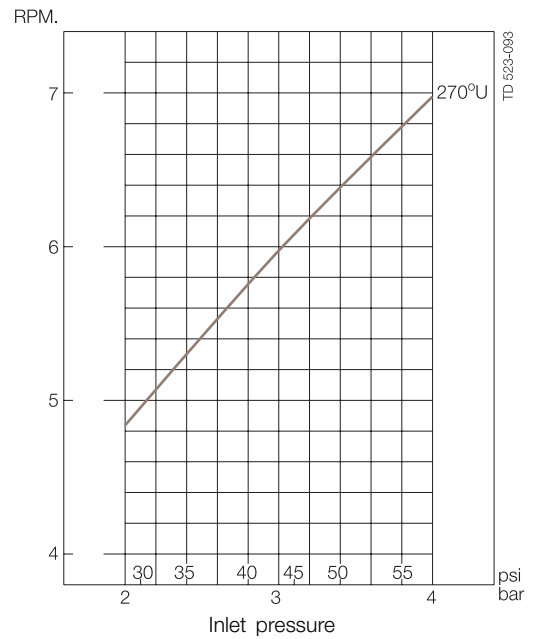

ESE00333EN 0901

The information contained herein is correct at the time of issue, but may be subject to change without prior notice.

**How to contact Alfa Laval**

Contact details for all countries are continually updated on our website. Please visit [www.alfalaval.com](http://www.alfalaval.com) to access the information direct.